

HESAI

www.hesaitech.com

JT16 & JT32

Mechanical Lidar Quick Start Guide

Classification: CO (Public)

Doc version: QSJ03-en-260410

Table of Contents

■ About this manual	1
■ Safety notice	3
Special warnings	3
Operating environment	5
Personnel	7
Installation and operation	8
Repair	12
■ How-to guides	13
1 Perform an initial check	13
1.1 Set up the hardware	13
1.1.1 Connect the cables	13
1.1.2 Install a driver on your computer	15
1.1.3 Check the current RS485 port number	17
1.2 View live point cloud	20
1.2.1 Install PandarView 2	20
1.2.2 Configure the network settings	21
2 Record a point cloud file	22
3 Play back a point cloud file	23
3.1 Load a PCAP file	23
3.2 Play the PCAP file	24
3.3 Apply point cloud correction	25

3.3.1 Apply angle correction (optional)	25
4 Use a GNSS clock source	26
4.1 Connect the cables	28
4.2 Check the timestamp output of the lidar	29
5 Communicate with the lidar	30
5.1 Set up the hardware	31
5.1.1 Connect the cables	31
5.1.2 Install a driver on your computer (Windows only)	33
5.1.3 Check the current RS485 and UART port numbers	33
5.2 Use LidarUtilities to communicate with the lidar	33
5.2.1 Install LidarUtilities	33
5.2.2 Connect the lidar	34
5.2.3 Send commands and receive responses	34
6 Clean the cover lens	35
7 Troubleshoot issues	37
Appendix A: Legal notice	39

■ About this manual



Should there be other agreements with specific users, the other agreements shall apply.



Before your first use

- Read through this manual.

Types of content

How-To Guides	Task-oriented instructions
Technical Reference	Structured product information
Explanation	Background and context

Formatting conventions

Warnings	 Instructions that must be followed to ensure safe and proper use of the product.
Notes	 Additional information that may be helpful.
Data fields	In monospace font: Distance represents the Distance field.

- Check the product's nameplate for certification information.
If an agreement exists not to display certification information on the nameplate, please follow the agreed-to arrangements.
- Confirm product development maturity with Hesai.
Hesai makes no warranty for products still in development.

When operating the product

- Follow all the instructions in this manual.
Failure to comply may result in product damage, property loss, personal injuries, and/or a breach of warranty.
- Seek technical support when needed.
 - service@hesaitech.com
 - <https://www.hesaitech.com/technical-support/>
 - <https://github.com/HesaiTechnology>

After upgrading the product

Get the latest version of this manual. Do one of the following:

- Ask your Hesai sales representative.
- Contact Hesai technical support at service@hesaitech.com.

When integrating the product into your application

- Provide this manual (or access to it) to the intended users of your product.
- This lidar product is intended as a component of an end product. The end-product supplier has these responsibilities:
 - Assessing the risk of use in accordance with applicable standards.
 - Informing the intended user of safety-related information.

■ Safety notice

Special warnings

Laser safety

CLASS 1 LASER PRODUCT

This product complies with IEC 60825-1:2014, EN 60825-1:2014+A11:2021, EN 50689:2021 and complies with FDA performance standards for laser products except for conformance with IEC 60825-1 Ed.3., as described in Laser Notice No.56, dated May 8, 2019.

Hot surface**Hot parts!**

Burned fingers when handling the parts.

Wait one-half hour after switching off before handling the parts.

Abnormalities

In any of the circumstances listed below, stop using the product immediately:

- If you suspect malfunctions of or damage to the product, with symptoms such as noticeable noise or vibration.
- If you or people in the nearby environment feel discomfort.
- If any device or equipment in the nearby environment malfunctions.

Meanwhile, contact Hesai or an authorized Hesai service provider for more information on product disposal.

Prohibition of disassembly

Unless expressly agreed to in writing by Hesai, do NOT disassemble the product.

Operating environment

Radio frequency (RF) interference

- Before using the product, make sure to read all the signs and notices on the product enclosure (including the nameplate). If specific users require not presenting certification information on the nameplate, please follow the agreed-to arrangements.

Vibration

- If significant mechanical shocks and vibration exist in the product's operating environment, please contact Hesai's technical support to obtain the shock and vibration limits of your product model. Exposure to over-the-limit shocks or vibration may damage the product.
- Make sure to package the product in shock-proof materials to avoid damage during transport.

Explosive atmosphere and other air conditions

- Do NOT use the product in any area where a potentially explosive atmosphere is present, such as where the air contains high concentrations of flammable chemicals, vapors, or particulates (including particles, dust, and metal powder).
- Do NOT expose the product to environments that have high concentrations of industrial chemicals, including liquefied gases that are easily vaporized (such as helium). Such exposure can damage or impair product functionality.

Chemical environment

Do NOT expose the product to corrosive or strong polar chemical environments (such as liquids or gases), including but not limited to strong acids, strong bases, esters, and ethers. This is to avoid damage to the product (including but not limited to water resistance failure).

Ingress protection (IP)

Please check the product's user manual for its IP rating. Make sure to avoid any ingress beyond that rating.

Operating temperature

Please check the product's user manual for its operating temperature. Make sure not to exceed the operating temperature range.

Recommended storage conditions

Please store the product in a dry and well-ventilated place. The recommended ambient temperature is $23 \pm 5^{\circ}\text{C}$, with relative humidity between 30% and 70% RH.

Light interference

Certain precision optical instruments may interfere with the laser light emitted from the product. Please check all the instructions for these instruments and take preventive measures if necessary. For example, protective leather covers are provided for certain product models; when these lidars are temporarily not used for measurement, the leather covers can be applied to block laser light emission.

Personnel

Recommended operator qualifications

The product should be operated by professionals with an engineering background or experience in operating optical, electrical, and mechanical instruments. Always follow the instructions in this manual throughout operation. If needed, please contact Hesai for technical support.

Medical device interference

- Some components in the product can emit electromagnetic fields. If the product operators or people in the nearby environment wear medical devices (such as cochlear implants, implanted pacemakers, and defibrillators), make sure to consult the physicians and medical device manufacturers for medical advice, such as determining whether a safe distance from the product is required.
- If you suspect that the product is interfering with your medical device, stop using the product immediately.

Installation and operation

Power supply

- Before powering on the product, make sure the electrical interfaces are dry and clean. Do NOT power on the product in a humid environment.
- Do NOT use damaged or out-of-spec cables or adapters.
- You are recommended to use only the cables and power adapters provided by Hesai. If you are to design, configure, or select a power supply system for the product, make sure to comply with the electrical specifications in the product's user manual.
- Please check the product's user manual and strictly follow the instructions on plugging/unplugging the connector. If abnormalities already exist (such as bent pins, broken cables, and loose threads), stop using the product and contact Hesai technical support.

Eye safety

The product is a Class 1 laser product. It satisfies the requirements of:

- IEC 60825-1:2014
- EN 60825-1:2014+A11:2021
- CONSUMER LASER PRODUCT EN 50689:2021
- 21 CFR 1040.10 and 1040.11 except for deviations (IEC 60825-1 Ed.3) pursuant to Laser Notice No.56, dated May 8, 2019.

CAUTION: Use of controls or adjustments or performance of procedures other than those specified herein may result in hazardous radiation exposure.

CAUTION

- For maximum self-protection, it is strongly warned that users do NOT look into the transmitting laser through a magnifying product (microscope, eye loupe, magnifying glass, etc.).
- This product does not have a power switch. It starts operating once connected to power. During operation, the entire cover lens can be regarded as the product's laser emitting window; looking at the cover lens can be regarded as looking into transmitting laser.

Product enclosure

- Do NOT crush or puncture the product. If the product enclosure is broken, stop using it immediately and contact Hesai technical support.
- Certain product models contain high-speed rotating parts. To avoid potential injuries, do NOT operate the product if the enclosure is loose.
- If the product enclosure consists of fins or grooves, please wear gloves when handling the product. Applying too much pressure with your bare hands may cause cuts, bruises or other injuries.

Drops and burns

The product contains metal, glass, and plastic, as well as sensitive electronic components. If the product is dropped or burnt, stop using it immediately and contact Hesai technical support.

Cover lens

- Do NOT apply protective film, wax or any other substance on the cover lens.
- To keep the product's cover lens from fingerprints and other stains, do NOT touch the cover lens with bare hands. If the cover lens is already stained, please refer to the cleaning method in [Section 6 Clean the cover lens](#).
- To prevent scratches, do NOT touch the product's cover lens with hard or sharp objects. If scratches already exist, stop using the product and contact Hesai technical support. Severe scratches may affect the quality of the product's point cloud data.

Mounting

- Before operating the product, make sure it is properly and securely mounted. The mounting should prevent the product from leaving its mounting position under external forces (such as collisions, high winds, and stone impacts).
- If the product is installed in a cavity designed as a wet zone, make sure that no water accumulates in the cavity.
- Before installing any exterior part, please ensure that each exterior part and its movable area do not overlap the Field of View (FOV) of the lidar.



The lidar's FOV is the spatial angular range bounded by the horizontal and vertical FOV ranges; the distance to the origin of the lidar's coordinate system is not limited. For inquiries about the FOV, please contact Hesai technical support.

Hot surface

During operation or the time period after the operation, the product's enclosure can be hot.

- To prevent discomfort or even burns, do NOT touch the product's enclosure with your skin.
- To prevent fires, make sure to keep flammable materials away from the product's enclosure.

Certain product models support active heating of the cover lens to reduce the impact of ice and frost.

- While active heating is ON, please avoid direct skin contact with the cover lens.
- Users can turn off active heating.

Peripherals

The product may be used along with accessories and devices, such as suction cup mounts, extension cables, power supplies, network devices, GNSS/PTP devices, CAN transceivers, and cleaning equipment.

When selecting a peripheral, please refer to all relevant specifications in the product's user manual or contact Hesai technical support. Using out-of-spec or unsuitable devices may result in product damage or even personal injuries.

Firmware and software upgrading

Make sure to use only the upgrade files provided by Hesai. Make sure to observe all the instructions provided for that upgrade file.

Customized firmware and software

- Before using a customized version of firmware and software, please fully understand the differences in functions and performance between the customized version and the standard version.
- Make sure to strictly follow all the instructions and safety precautions provided for that customized version. If the product does not function as anticipated, stop using the product immediately and contact Hesai technical support.

Point cloud data processing

- Certain product models support one or more point cloud data processing functions, including but not limited to: Noise Filtering, Interstitial Points Filtering, Retro Multi-Reflection Filtering, and Nonlinear Reflectivity Mapping.
- These functions are configurable and are intended only to assist the user in extracting information from the point cloud data. Users are in full control of whether to use any of these functions. Moreover, users are responsible for analyzing the product's intended application scenarios and evaluating the risk of enabling one or more of these functions in combination.
- To learn about the supported functions of a product model, please contact Hesai technical support.

Repair

- Unless expressly agreed to in writing by Hesai, do NOT disassemble, repair, modify, or retrofit the product by yourself or entrust any third party to do so. Such a breach:
 - can result in product damage (including but not limited to water resistance failure), property loss, and/or injuries;
 - shall constitute a breach of warranty.
- For more product repair issues, please contact Hesai or an authorized Hesai service provider.

■ How-to guides

1 Perform an initial check

After unboxing, follow this section to view the point cloud of your lidar.

Preparation

Where	Item	Notes
In the box	Lidar unit	-
	Connection box	-
	USB-to-RS485 cable	-
	Power adapter	If your order does not include a power adapter, use a portable power source (12 to 16 V) instead.
From your side	Computer	Operating system: <ul style="list-style-type: none"> • 64-bit Windows 10/11 • Ubuntu 20.04/22.04/24.04

1.1 Set up the hardware

1.1.1 Connect the cables



- The lidar has no power switch. It outputs data as soon as you power it and connect it to a host computer.
- The Lidar's appearance is for reference only. The actual product may vary.

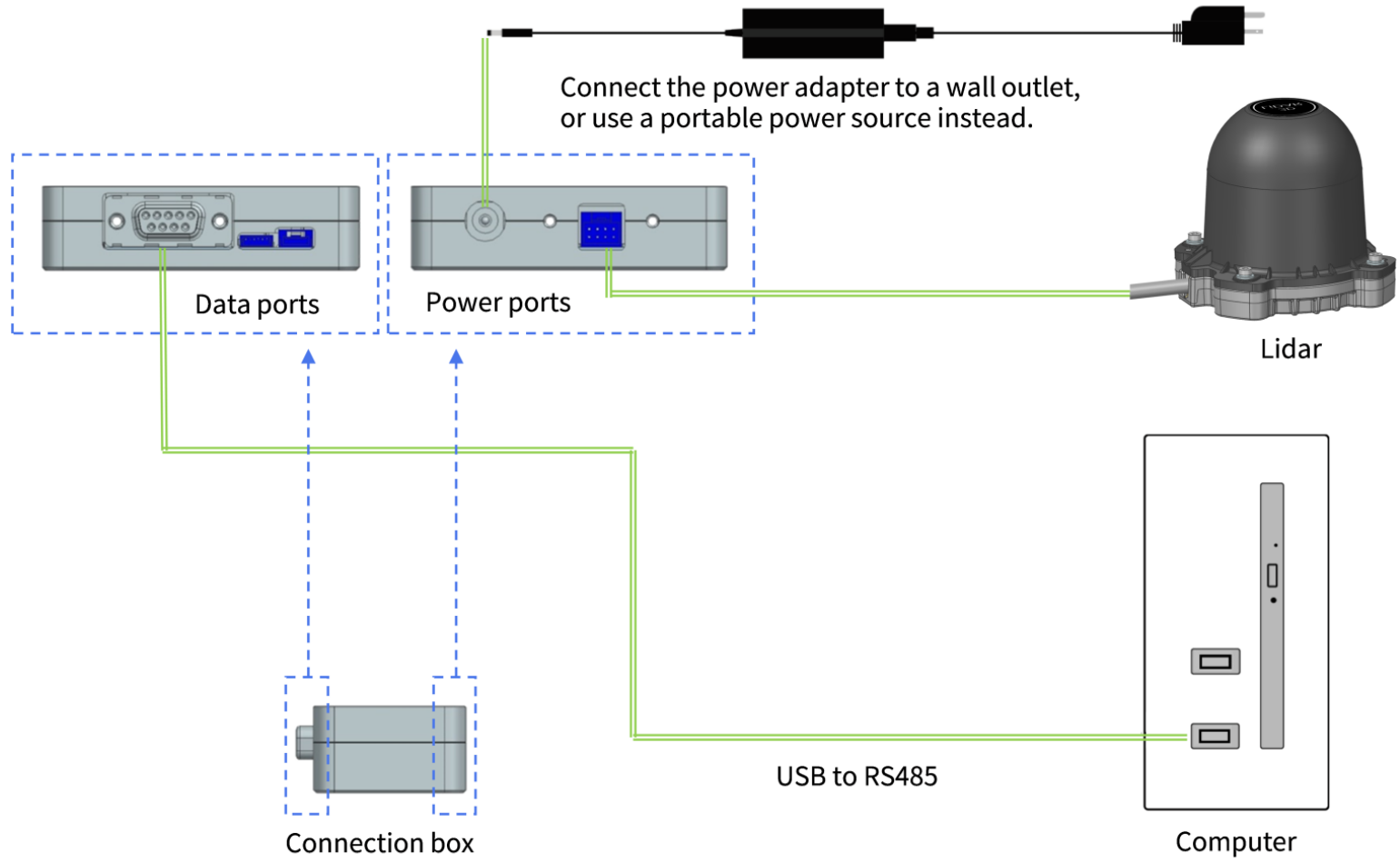

Figure 1. Connection

1.1.2 Install a driver on your computer

The USB-to-RS485 cable contains a third-party chip. Your computer needs a driver to drive the chip.

In Windows

1. Download the driver.
 - a. Download the driver [here](#), which contains multiple drivers.
 - b. In the ZIP file, find the folder that matches your operating system version.
 - c. Copy this folder into a local directory.
2. Install the driver.
 - a. Open the Computer Management.



Type "Computer Management" in the search box on the taskbar.

- b. Click [**Device Manager**].
- c. In the list of devices, double-click to expand [**Other devices**].
- d. Right-click [**USB-Serial Controller**] and select [**Update Driver Software**].
- e. Select [**Browse my computer for drivers**].
- f. Select the driver you copied into a local directory and click [**Next**].
- g. Wait for the driver to install.

In Ubuntu

1. Check if a built-in driver exists.
 - a. Open a terminal.
 - b. Type this command (to see your Linux kernel version):

```
uname -r
```

- If your kernel version is 5.5 or later, the driver is already built in. Skip the rest of the steps.

- If your kernel version is between 2.6.15 and 5.4, go to Step 2.
2. Download the driver.
 - a. Download the ZIP file [here](#), which contains multiple drivers.
 - b. In the ZIP file, find the folder that matches your Linux kernel version.
 - c. Copy this folder into a local directory.
 3. Install the driver.
 - a. In the local directory, open a terminal and run this command (to gain root privileges):

```
sudo su
```

- b. Run this command (to compile and install the driver):

```
make all
```

- c. Run this command (to open the kernel modules file in a text editor):

```
sudo gedit /etc/modules
```

- d. Type "pl2303" on a new line at the end of the file.
 - e. Save the file and close the text editor.
4. Restart the Ubuntu system.
5. Reconnect the USB-to-RS485 cable.

1.1.3 Check the current RS485 port number

In Windows

Method 1

1. View all the serial ports.
 - a. Open the Command Prompt.

 Press **Win + R** (to open the Run dialog), type "cmd" and press [**Enter**].

- b. Run this command:

```
mode
```

2. Plug and unplug the RS485 cable to find out its serial port number.
 - Port number format: "COM" + number

```
C:\Users\>mode
Status for device COM4:
-----
Baud:           1200
Parity:         None
Data Bits:      7
Stop Bits:      1
```

Method 2

1. Open the Device Manager.

 Type "Device Manager" in the search box on the taskbar.

2. In the list of devices, double-click to expand [**Ports (COM & LPT)**].
3. Look for the RS485 port.
 - The port name usually includes the chipset model of a USB-to-RS485 converter.
 - Port number format: "COM" + number

In Ubuntu

1. View all the serial ports and their permissions.
 - a. Open a terminal.
 - b. Run this command:

```
ls -l /dev/ttyUSB*
```

- Any port that begins with "crw-rw-rw-" is enabled.
- Any port that begins with "crw-rw----" is disabled.

```

:~$ ls -l /dev/ttyUSB*
crw-rw---- 1 root dialout 188, 0 Oct 31 17:04 /dev/ttyUSB0
crw-rw---- 1 root dialout 188, 1 Oct 31 17:04 /dev/ttyUSB1
    
```

Figure 2. Disabled serial ports

```

:~$ ls -l /dev/ttyUSB*
crw-rw-rw- 1 root dialout 188, 0 Oct 31 17:08 /dev/ttyUSB0
crw-rw-rw- 1 root dialout 188, 1 Oct 31 17:08 /dev/ttyUSB1
    
```

Figure 3. Enabled serial ports

2. If some serial ports are disabled, run this command (to enable all the serial ports):

```
sudo chmod 666 /dev/ttyUSB*
```

3. Optional: Repeat Step 1 to confirm.
4. Plug and unplug the RS485 cable to find out its serial port number.
 - Port number format: "/dev/ttyUSB" + number
5. Repeat Step 2 to enable all the serial ports again.

1.2 View live point cloud

1.2.1 Install PandarView 2

Use the PandarView 2 software to view and record point cloud data from Hesai lidars.

1. Ask Hesai technical support to get the installation package.
2. Install PandarView 2.





In Ubuntu, run "PandarView.sh" in a file path that only contains ASCII characters.

3. Turn off the computer's firewall for public networks, or add PandarView 2 to firewall exceptions.

1.2.2 Configure the network settings

In PandarView 2:

1. Click  [**Listen for Data**] in the toolbar.
2. In the dialog, input these parameters:

Serial Port	<p>Check the checkbox and input the RS485 port number.</p> <div style="border: 1px dashed #ccc; padding: 5px;"> <ul style="list-style-type: none"> • Refer to Check the current RS485 port number • Format of a serial port number: <ul style="list-style-type: none"> ◦ In Windows: "COM" + number ◦ In Ubuntu: "/dev/ttyUSB" + number </div>
Baud Rate	<p>JT16 — 3000000 JT32 — 5000000</p> <div style="border: 1px dashed #ccc; padding: 5px;"> <p> For customized models or certain software versions, refer to the <i>User Manual</i>.</p> </div>

3. Click [**OK**] to start viewing live point cloud.

Troubleshoot issues

- [The live point cloud is blank in PandarView 2.](#)
- [The live point cloud is abnormal, showing obviously misaligned points, flashing points, or incomplete FOV.](#)

2 Record a point cloud file

Before you begin

Complete the steps in [Section 1 Perform an initial check](#) so that you can view live point cloud.

In PandarView 2:

1. Click the [**Record**] button at the bottom left of the window.

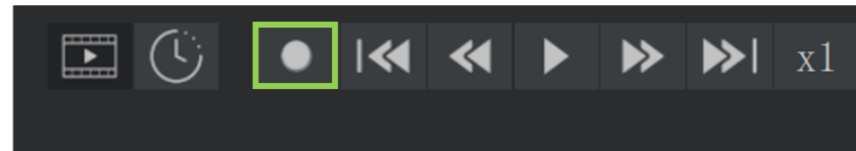

2. Specify a file directory.
3. Click [**Save**] to start recording a PCAP file.



When naming PCAP files in Ubuntu, include the filename extension (.pcap).

3 Play back a point cloud file

In PandarView 2:

3.1 Load a PCAP file

Method 1	Method 2
Click  [Open File] in the toolbar and select a PCAP file.	Drag a PCAP file into PandarView 2.



- Only one file at a time.
During playback, if you load another PCAP file or switch to receiving live point cloud, the previous file will be closed.
- Large PCAP files may take a while to load.
To stream point cloud data while loading the file, click  [**Live Streaming**].

Troubleshoot issues

[When loading a PCAP file, PandarView 2 gives an error message "invalid file; unable to parse file".](#)

3.2 Play the PCAP file

Click the [**Play**] button at the bottom left of the window.

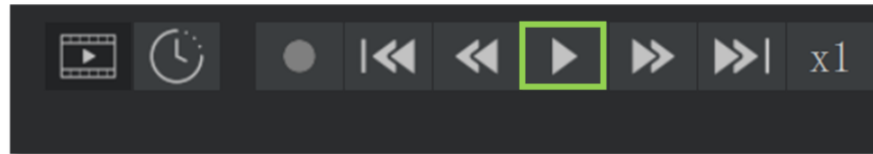

3.3 Apply point cloud correction

3.3.1 Apply angle correction (optional)

Do these steps to correct the azimuth and elevation of each data point:

1. Contact Hesai technical support to get the angle correction file of your lidar unit.
2. Click  [**Correction**] in the toolbar.
3. Click [**Import**] under "Angle Correction".
4. Upload the correction file.

Get the angle correction file

Use one of these ways:

- See the API Reference Manual.
- Export the file using PandarView 2; see the PandarView 2 User Manual.
- Ask Hesai technical support or your sales representative.

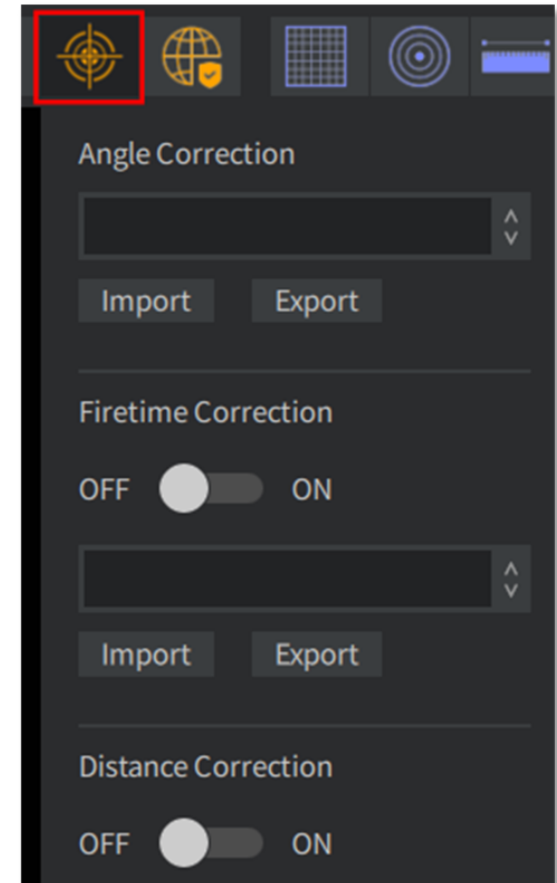

4 Use a GNSS clock source

Follow this section to add a GNSS clock source to your lidar.
Afterwards, your lidar will output point cloud data with absolute timestamps.

Before you begin

Complete the steps in [Section 1 Perform an initial check](#) so that you can view live point cloud.

Additional preparation

Where	Item	Notes									
From your side	GNSS module	Should be able to provide these signals:									
		<table border="1"> <thead> <tr> <th>Signal</th> <th>Level</th> <th>Format</th> </tr> </thead> <tbody> <tr> <td>PPS</td> <td>3.3 V CMOS</td> <td>-</td> </tr> <tr> <td>NMEA</td> <td>RS232</td> <td>GPRMC or GNRMC</td> </tr> </tbody> </table>	Signal	Level	Format	PPS	3.3 V CMOS	-	NMEA	RS232	GPRMC or GNRMC
		Signal	Level	Format							
		PPS	3.3 V CMOS	-							
NMEA	RS232	GPRMC or GNRMC									

Timing requirements of GNSS signals (PPS and NMEA)

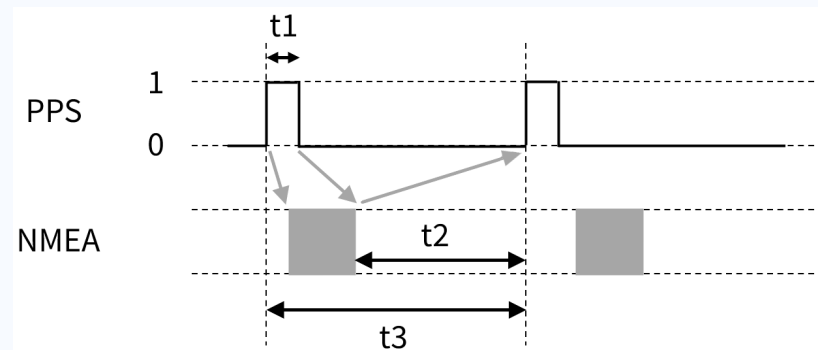

Cycle of the PPS signal	$t_3 = 1 \text{ s} \pm 50 \mu\text{s}$ (rising edge to rising edge)
Pulse width of the PPS signal	$t_1 \geq 1 \text{ ms}$ Recommended range: 10 to 100 ms
Timing relationship	As indicated by the gray arrows, the NMEA signal: <ul style="list-style-type: none"> • Should start after the PPS rising edge of the current second. • Should end after the PPS falling edge of the current second. • Should end before the PPS rising edge of the next second; $t_2 \geq 500 \text{ ms}$.

4.1 Connect the cables

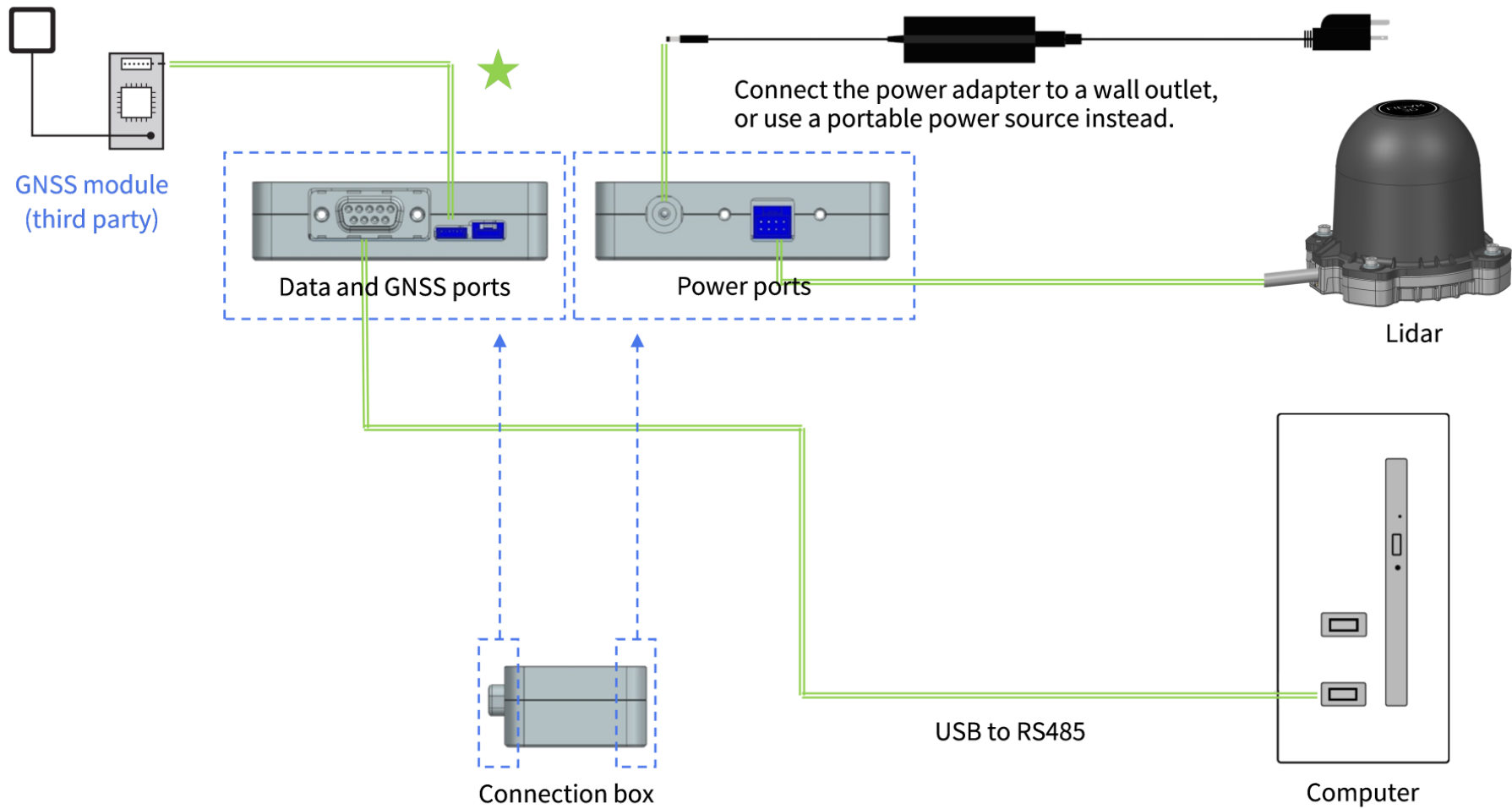

Figure 4. Connection

To connect the wires marked with ★ in [Figure 4](#), refer to the pin description (left to right) of this connection box port:

Pin number	Direction	Signal	Level	Description
1	Input	GNSS_PPS	3.3 V CMOS	-
2	Output	GNSS_5V	5 V	Power for the external GNSS module
3	-	GND	0 V	Ground for the external GNSS module
4	Input	GNSS_NMEA	RS232	-
5	-	GND	0 V	Ground for the external GNSS module
6	-	Reserved	-	Do NOT connect this pin to external signals.

4.2 Check the timestamp output of the lidar

In PandarView 2:

1. [View live point cloud](#)
2. Check if the timestamp is correctly shown at the bottom of the window:

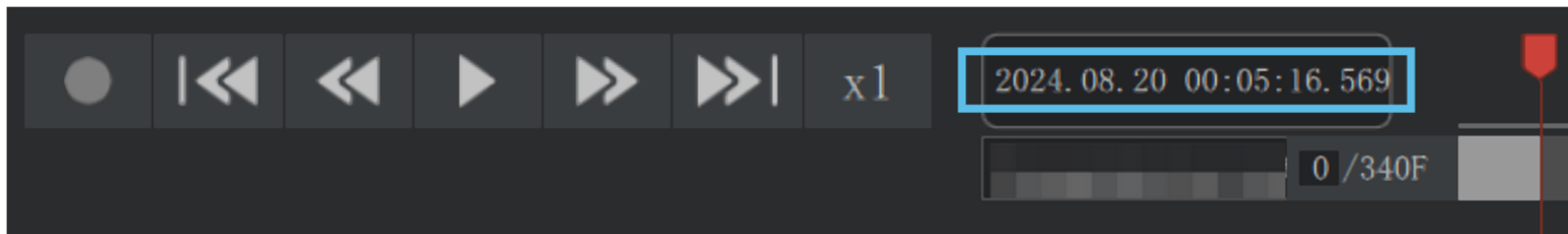

5 Communicate with the lidar

Follow this section to:

- Check device info.
- Monitor operating status.
- View or modify settings.
- Upgrade firmware and software.

The lidar provides a serial interface API for such communication. Use one of these methods to access the API:

- LidarUtilities (a graphical tool for host computers; recommended)
- A software debugger
- Command-line tools or custom scripts

Before you begin

Complete the steps in [Section 1 Perform an initial check](#) so that you can view live point cloud.

Additional preparation

Where	Item	Notes
In the box	USB-to-UART module with jumper wires	-

5.1 Set up the hardware

5.1.1 Connect the cables



When using API, do not connect any GNSS module to the lidar.

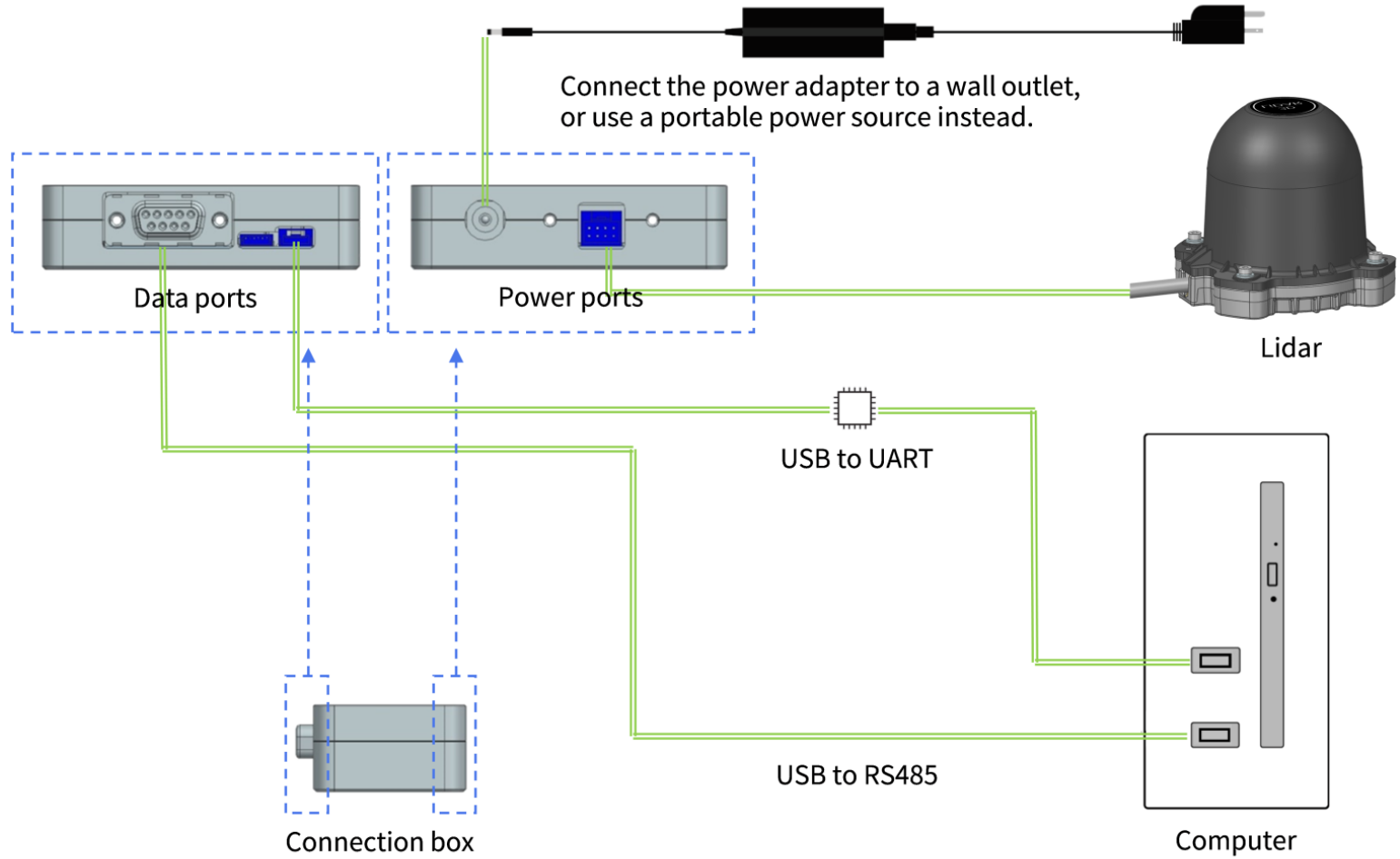

Figure 5. Connection

5.1.2 Install a driver on your computer (Windows only)

The USB-to-UART module includes a third-party chip. Your computer needs a driver to drive the chip.

Download the driver [here](#) and install it.

5.1.3 Check the current RS485 and UART port numbers

In Windows

1. View all the serial ports.
 - a. Open the Command Prompt.
 - b. Run this command:

```
mode
```

2. Plug and unplug the RS485 cable to find out its serial port number.
 - Port number format: "COM" + number
3. Plug and unplug the UART cable to find out its serial port number.

5.2 Use LidarUtilities to communicate with the lidar

5.2.1 Install LidarUtilities

Download it at: <https://www.hesaitech.com/downloads/>

5.2.2 Connect the lidar

At the top of the LidarUtilities window, input the [port numbers](#) and baud rates for UART and RS485 communication, and click **Connect**.

Baud rate:

- RS485: 3000000/5000000 bps (may be different for customized models or certain software versions; refer to the respective user manual)
- UART (shown as RS232): 9600 bps

5.2.3 Send commands and receive responses

Use the **Home** and **Settings** pages to do these tasks:

- Check device info.
- Monitor operating status.
- View or modify settings.

Use the **Upgrade** page to upgrade firmware and software.

Alternatively, use the **Debug** page to send and receive raw serial data.



The available commands are in the lidar's *API Reference Manual*.

6 Clean the cover lens

The lidar's cover lens is made of plastic (polycarbonate, PC).

- Do NOT wipe the cover lens when it is dry, nor use abrasive cleaners. Doing so can damage the optical coating.
- Do NOT use organic cleaners, which can damage the cover lens and even cause cracking.
 - Organic cleaners include but are not limited to tar removers, self-cleaning agents, adhesive removers, coating removers, foam cleaners, iron powder removers for car paint, glass cleaners, thinning agents, de-icers, paint surface treatment agents, alcohol, and vinegar.
 - If organic cleaners may be present when cleaning the equipment or performing related operations, please protect the cover lens to prevent any contact with organic cleaners.
- Do NOT apply excessive force to the lidar, as this can damage the cover lens.
 - Using automatic cleaning devices that are not specifically designed for lidars may pose risks. Please contact Hesai technical support for assessment.
 - Do NOT use sharp objects (such as knives or metal tweezers) or hard brushes (such as stiff nylon brushes or wire brushes) to scratch the cover lens cover surface. Such actions may damage the cover lens surface, and in severe cases, may cause malfunction.
- After prolonged exposure to strong sunlight and high temperatures, the cover lens should NOT be cleaned immediately.
- If snow or ice accumulates on the cover lens, do NOT use a pressure washer or ice scraper.
 - A small broom is recommended to remove snow.
 - A solvent-free (i.e., free of organic solvents) ice removal spray is recommended to remove ice; alternatively, wait for the ice to melt by itself.
- Do NOT wax the cover lens.



Please regularly check on the cover lens, considering your use frequency, storage environment, and climate conditions.



- If foreign objects (such as dust, fingerprints, or oil stains) are found on the cover lens, make sure to clean them.
- If corrosive foreign objects (such as insect remains, bird droppings, tree resin, road dust, industrial dust, asphalt, soot particles, and road salt) are found on the cover lens, make sure to clean them immediately.

Cleaning procedure

1. Make sure the lidar is powered OFF.
2. Choose an appropriate cleaning agent:
 - For light stains, use room temperature water.
 - For heavier stains, use a mild soap solution (no more than two tablespoons of soap per quart or liter of water).
 - For stubborn stains, use a solvent-free (i.e., free of organic solvents), pH-neutral detergent at room temperature, such as car shampoo.
3. Take a clean soft sponge or anti-static microfiber cloth, dampen it with the chosen cleaning agent, and gently wipe the dirty area on the cover lens back and forth.
4. For stubborn stains, cover the dirty area with the dampened sponge or cloth to soften the stains before wiping.
5. Immediately after removing the stains, rinse the cover lens with clean water. Then, use a clean soft sponge or microfiber cloth to gently wipe away any remaining liquid (which may contain residual cleaning agents or contaminants).

7 Troubleshoot issues

If these procedures do not resolve your issue, please contact Hesai technical support.

The live point cloud is blank in PandarView 2.

1. Verify the network settings.

Make sure these conditions are met:

- The RS485 port number and baud rate are correct in [PandarView 2 network settings](#).
- The computer's firewall for public networks is turned off, or PandarView 2 is added to firewall exceptions.
- In Ubuntu, the RS485 port is enabled (see [Check the current RS485 port number in Ubuntu](#)).

2. Test the physical connection.

Make sure the indicator light is ON on the connection box. If not, try these methods:

- Unplug and plug all connectors.
- Use another computer.
- Use another connection box.
- Use another power adapter.
- Use another lidar.

3. Check for laser emission.

Use one of these tools to confirm that the lidar is emitting laser light:

- Infrared camera
- Infrared sensor card
- Phone camera without an IR-cut filter

4. Use a serial port monitor software to view the raw point cloud data.

- a. In the software, input the [RS485 port number and baud rate](#).
- b. View the raw data of the port in hex format.
- c. If the first four bytes are not "EE FF 01 08", check if the [USB-to-RS485 driver](#) is correctly installed.

The live point cloud is abnormal, showing obviously misaligned points, flashing points, or incomplete FOV.

1. Inspect the cover lens.

If the cover lens is contaminated, follow the cleaning procedure in [Section 6 Clean the cover lens](#).

2. Confirm that the motor speed is stable.

Analyze the motor speed data in the **TDM Data** field of Point Cloud Data Packets.

3. Check for packet loss.

If no packet is lost while the point cloud still flashes, try these steps:

- a. Install the latest PandarView 2 (see [Install PandarView 2](#)).
- b. Restart the computer.

4. Test the physical connection.

Try these methods:

- Connect the lidar to another computer.
- Use another USB to RS485 cable.

When loading a PCAP file, PandarView 2 gives an error message "invalid file; unable to parse file".

If the file is not generated by PandarView 2, follow these steps:

1. Open the file using a hex viewer.
2. Check if the first four bytes are "D4 C3 B2 A1" (little endian) or "A1 B2 C3 D4" (big endian).
 - If not, then the file is not in **tcpdump PCAP** format and is not supported by PandarView 2.
 - As a temporary solution, import this file into WireShark and export it as a tcpdump PCAP file.

Appendix A: Legal notice

Copyright © 2017-2026 Hesai Technology Co., Ltd.

All rights reserved. Use or reproduction of this manual in parts or its entirety in any form or by any means without the written authorization of Hesai is prohibited.

Hesai Technology makes no representations or warranties, either expressed or implied, with respect to the contents hereof and specifically disclaims any warranties, merchantability, or fitness for any particular purpose. Further, Hesai Technology reserves the right to revise this publication and to make changes from time to time in the contents hereof without obligation to notify any person of such revisions or changes.

HESAI and HESAI logo are registered trademarks of Hesai Technology. All other trademarks, service marks, and company names in this manual or on Hesai's official website are properties of their respective owners.

The software included in this product contains copyright that is registered under Hesai Technology. Any third party is not permitted, except as expressly permitted by the licensor or expressly required by applicable law, to decompile, reverse engineer, disassemble, modify, rent, lease, loan, distribute, sublicense, create derivative works based on the whole or any part of the software.

Hesai Product Warranty Service Manual is on the Warranty Policy page of Hesai's official website: <https://www.hesaitech.com/warranty-policy/>

Hesai Technology Co., Ltd.

Phone: +86 400 805 1233

Website: www.hesaitech.com

Address: Building A, Haisu Culture Plaza, Shanghai, China

Business Email: info@hesaitech.comService

Email: service@hesaitech.com