

HESAI

www.hesaitech.com

QT128C2X

128-Channel Mechanical Lidar User Manual

Classification: CO (Public)

Doc version: Q03-en-260410

Table of Contents

■ About this manual	1
Access to this manual	1
Technical support	1
Legends and format	1
■ Safety notice	2
Special warnings	2
Operating environment	3
Personnel	5
Installation and operation	5
Repair	9
1 Introduction	10
1.1 Applicability	10
1.2 Operating principle	10
1.3 Basic structure	11
1.4 Channel distribution	12
1.5 Specifications	14
2 Setup	17
2.1 Mechanical installation	17
2.1.1 Exterior dimensions	17
2.1.2 Recommended installation	19
2.1.3 Notes on screw installation	21
2.2 Electrical interface	22
2.2.1 Pin description	23
2.2.2 Connector use	24
2.2.3 Cables (Ethernet)	26

2.3 Connection box (optional)	27
2.3.1 Ports	28
2.3.2 Connection	30
2.4 Network settings on the host computer	32
2.4.1 In Windows	33
2.4.2 In Ubuntu	35
2.5 Tools	38
3 Data structure	39
3.1 Point cloud data packet	40
3.1.1 Ethernet Header	40
3.1.2 Point cloud UDP data	41
3.1.3 Ethernet tail	50
3.1.4 Point cloud data analysis method	51
4 Web Control	54
4.1 Home	55
4.2 Settings	57
4.2.1 Network	59
4.2.2 Function	60
4.2.3 Time sync	63
4.3 Azimuth FOV	65
4.3.1 For All Channels	66
4.3.2 Multi-section FOV	66
4.4 Operation Statistics	67
4.5 Monitor	68
4.6 Upgrade	68
4.7 Log	70
4.8 Security	71

4.8.1 Login control	73
4.8.2 Secure Connection	74
4.8.3 Point cloud signature	75
4.8.4 Configure HTTPS environment	76
4.9 Login	80
5 Maintenance	81
6 Troubleshooting	83
Appendix A: Channel distribution data	87
A.1 Angle correction file	95
Appendix B: Absolute time of point cloud data	97
B.1 Source of absolute time	97
B.1.1 PTP as the clock source	97
B.2 Absolute time of the Point Cloud Data Packets	98
B.3 Start time of each block	98
B.4 Firing Sequences	98
B.5 Firing time offset of each channel	99
B.5.1 Firetime correction file	99
Appendix C: Power supply requirements	105
C.1 Input voltage	105
C.1.1 Estimate the minimum source voltage	105
C.1.2 Avoid overvoltage	106
C.2 Input power	106
Appendix D: Legal notice	107

■ About this manual

Please make sure to read through this user manual before your first use and follow the instructions herein when you operate the product. Failure to comply with the instructions may result in product damage, property loss, personal injuries, and/or a breach of warranty.

Access to this manual

To obtain the latest version, please do one of the following:

- Visit the Download page of Hesai's official website: <https://www.hesaitech.com/downloads/>
- Contact your sales representative of Hesai.
- Contact Hesai technical support at service@hesaitech.com.

Technical support

If your question is not addressed in this user manual, please contact us at:

- service@hesaitech.com
- <https://www.hesaitech.com/technical-support/>
- <https://github.com/HesaiTechnology>

Legends and format



Warnings: Instructions that must be followed to ensure safe and proper use of the product.



Notes: Additional information that may be helpful.

Names of data fields are in monospace font.

For example: **Distance** represents the Distance field.

■ Safety notice

- Please make sure to read through this safety notice and follow all the instructions and warnings. Failure to comply with the instructions and warnings may result in product damage, property loss, and/or personal injuries.
- Please check the certification information on the product's nameplate. If an agreement has been made not to present certification information on the nameplate, please follow the agreed-to arrangements.
- If you incorporate this lidar product into your product(s), you are required to provide this user manual (or access to this user manual) to the intended users of your product(s).
- This lidar product is intended as a component of an end product. The end-product supplier is responsible for assessing the risk of use in accordance with applicable standards and informing the intended user of safety-related information.
- Should there be other agreements with specific users, the other agreements shall apply.
- Before using a product, please confirm with Hesai the development maturity of the product in a timely manner. For products still in development, Hesai makes no warranty of non-infringement nor assumes any responsibility for quality assurance.

Special warnings

Laser safety

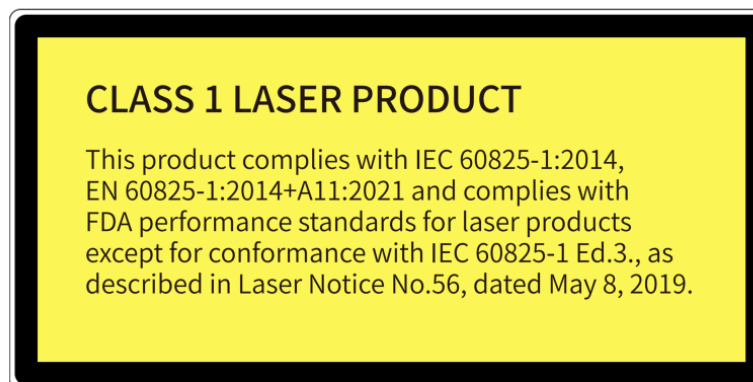

Hot surface



Hot parts!

Burned fingers when handling the parts.

Wait one-half hour after switching off before handling the parts.

Abnormalities

In any of the circumstances listed below, stop using the product immediately:

- If you suspect malfunctions of or damage to the product, with symptoms such as noticeable noise or vibration.
- If you or people in the nearby environment feel discomfort.
- If any device or equipment in the nearby environment malfunctions.

Meanwhile, contact Hesai or an authorized Hesai service provider for more information on product disposal.

Prohibition of disassembly

Unless expressly agreed to in writing by Hesai, do NOT disassemble the product.

Operating environment

Radio frequency (RF) interference

- Before using the product, make sure to read all the signs and notices on the product enclosure (including the nameplate). If specific users require not presenting certification information on the nameplate, please follow the agreed-to arrangements.
- Although the product is designed, tested, and manufactured to comply with the regulations on RF radiation (such as FCC, CE-EMC, or KCC), the radiation from the product may still influence electronic devices.

Vibration

- If significant mechanical shocks and vibration exist in the product's operating environment, please contact Hesai's technical support to obtain the shock and vibration limits of your product model. Exposure to over-the-limit shocks or vibration may damage the product.
- Make sure to package the product in shock-proof materials to avoid damage during transport.

Explosive atmosphere and other air conditions

- Do NOT use the product in any area where a potentially explosive atmosphere is present, such as where the air contains high concentrations of flammable chemicals, vapors, or particulates (including particles, dust, and metal powder).
- Do NOT expose the product to environments that have high concentrations of industrial chemicals, including liquefied gases that are easily vaporized (such as helium). Such exposure can damage or impair product functionality.

Chemical environment

Do NOT expose the product to corrosive or strong polar chemical environments (such as liquids or gases), including but not limited to strong acids, strong bases, esters, and ethers. This is to avoid damage to the product (including but not limited to water resistance failure).

Ingress protection (IP)

Please check the product's user manual for its IP rating (refer to [Section 1.5 Specifications](#)). Make sure to avoid any ingress beyond that rating.

Operating temperature

Please check the product's user manual for its operating temperature (refer to [Section 1.5 Specifications](#)). Make sure not to exceed the operating temperature range.

Recommended storage conditions

Please store the product in a dry and well-ventilated place. The recommended ambient temperature is $23 \pm 5^{\circ}\text{C}$, with relative humidity between 30% and 70% RH.

Light interference

Certain precision optical instruments may interfere with the laser light emitted from the product. Please check all the instructions for these instruments and take preventive measures if necessary. For example, protective leather covers are provided for certain product models; when these lidars are temporarily not used for measurement, the leather covers can be applied to block laser light emission.

Personnel

Recommended operator qualifications

The product should be operated by professionals with an engineering background or experience in operating optical, electrical, and mechanical instruments. Always follow the instructions in this manual throughout operation. If needed, please contact Hesai for technical support.

Medical device interference

- Some components in the product can emit electromagnetic fields. If the product operators or people in the nearby environment wear medical devices (such as cochlear implants, implanted pacemakers, and defibrillators), make sure to consult the physicians and medical device manufacturers for medical advice, such as determining whether a safe distance from the product is required.
- If you suspect that the product is interfering with your medical device, stop using the product immediately.

Installation and operation

Power supply

- Before powering on the product, make sure the electrical interfaces are dry and clean. Do NOT power on the product in a humid environment.
- Do NOT use damaged or out-of-spec cables or adapters.
- You are recommended to use only the cables and power adapters provided by Hesai. If you are to design, configure, or select the power supply system (including cables) for the product, make sure to comply with the electrical specifications in the product's user manual (refer to [Section 1.5 Specifications](#) and the Power Supply Requirements section if available); for technical support, please contact Hesai.
- Please check [Section 2.2 Electrical interface](#) and strictly follow the instructions on plugging/unplugging the connector. If abnormalities already exist (such as bent pins, broken cables, and loose threads), stop using the product and contact Hesai technical support.

Eye safety

The product is a Class 1 laser product. It satisfies the requirements of:

- IEC 60825-1:2014
- EN 60825-1:2014+A11:2021
- 21 CFR 1040.10 and 1040.11 except for deviations (IEC 60825-1 Ed.3) pursuant to Laser Notice No.56, dated May 8, 2019.

CAUTION: Use of controls or adjustments or performance of procedures other than those specified herein may result in hazardous radiation exposure.

CAUTION

- For maximum self-protection, it is strongly warned that users do NOT look into the transmitting laser through a magnifying product (microscope, eye loupe, magnifying glass, etc.).
- This product does not have a power switch. It starts operating once connected to power. During operation, the entire cover lens can be regarded as the product's laser emitting window; looking at the cover lens can be regarded as looking into transmitting laser.

Product enclosure

- Do NOT crush or puncture the product. If the product enclosure is broken, stop using it immediately and contact Hesai technical support.
- Certain product models contain high-speed rotating parts. To avoid potential injuries, do NOT operate the product if the enclosure is loose.
- If the product enclosure consists of fins or grooves, please wear gloves when handling the product. Applying too much pressure with your bare hands may cause cuts, bruises or other injuries.

Drops and burns

The product contains metal, glass, and plastic, as well as sensitive electronic components. If the product is dropped or burnt, stop using it immediately and contact Hesai technical support.

Cover lens



The location of the cover lens is illustrated in [Section 1 Introduction](#).

- Do NOT apply protective film, wax or any other substance on the cover lens.
- To keep the product's cover lens from fingerprints and other stains, do NOT touch the cover lens with bare hands. If the cover lens is already stained, please refer to the cleaning method in [Section 5 Maintenance](#).
- To prevent scratches, do NOT touch the product's cover lens with hard or sharp objects. If scratches already exist, stop using the product and contact Hesai technical support. Severe scratches may affect the quality of the product's point cloud data.

Mounting

- Before operating the product, make sure it is properly and securely mounted. The mounting should prevent the product from leaving its mounting position under external forces (such as collisions, high winds, and stone impacts).
- If the product is installed in a cavity designed as a wet zone, make sure that no water accumulates in the cavity.
- Before installing any exterior part, please ensure that each exterior part and its movable area do not overlap the Field of View (FOV) of the lidar.



The lidar's FOV is the spatial angular range bounded by the horizontal and vertical FOV ranges (see [Section 1.5 Specifications](#)); the distance to the origin of the lidar's coordinate system is not limited. For inquiries about the FOV, please contact Hesai technical support.

Hot surface

During operation or the time period after the operation, the product's enclosure can be hot.

- To prevent discomfort or even burns, do NOT touch the product's enclosure with your skin.
- To prevent fires, make sure to keep flammable materials away from the product's enclosure.

Certain product models support active heating of the cover lens to reduce the impact of ice and frost.

- While active heating is ON, the cover lens can be hot. To prevent discomfort or even burns, avoid direct skin contact with the cover lens.
- When the cover lens is free of ice and frost, you may turn off active heating.

Peripherals

The product may be used along with accessories and devices, such as suction cup mounts, extension cables, power supplies, network devices, GNSS/PTP devices, CAN transceivers, and cleaning equipment.

When selecting a peripheral, please refer to all relevant specifications in the product's user manual or contact Hesai technical support. Using out-of-spec or unsuitable devices may result in product damage or even personal injuries.

Firmware and software upgrading

Make sure to use only the upgrade files provided by Hesai. Make sure to observe all the instructions provided for that upgrade file.

Customized firmware and software

- Before using a customized version of firmware and software, please fully understand the differences in functions and performance between the customized version and the standard version.
- Make sure to strictly follow all the instructions and safety precautions provided for that customized version. If the product does not function as anticipated, stop using the product immediately and contact Hesai technical support.

Point cloud data processing

- Certain product models support one or more point cloud data processing functions, including but not limited to: Noise Filtering, Interstitial Points Filtering, Retro Multi-Reflection Filtering, and Nonlinear Reflectivity Mapping.
- These functions are configurable and are intended only to assist the user in extracting information from the point cloud data. Users are in full control of whether to use any of these functions. Moreover, users are responsible for analyzing the product's intended application scenarios and evaluating the risk of enabling one or more of these functions in combination.
- To learn about the supported functions of a product model, please contact Hesai technical support.

Repair

- Unless expressly agreed to in writing by Hesai, do NOT disassemble, repair, modify, or alter the product by yourself or through any third party. Such a breach:
 - can result in product damage (including but not limited to water resistance failure), property loss, and/or injuries;
 - shall constitute a breach of warranty.
- For more product repair issues, please contact Hesai or an authorized Hesai service provider.

1 Introduction

1.1 Applicability

This manual applies to the following versions:

Software	3.1.66 or later
Firmware of Sensor	3.1.36 or later
Firmware of Controller	3.1.40 or later

1.2 Operating principle

Distance measurement: Time of Flight (ToF)

1. A laser diode emits a beam of ultrashort laser pulses onto the target object.
2. The laser pulses are reflected after hitting the target object. The returning beam is detected by an optical sensor.
3. Distance to the object can be accurately measured by calculating the time between laser emission and receipt.

$$d = \frac{ct}{2}$$

d: Distance

c: Speed of light

t: Travel time of the laser beam

1.3 Basic structure

The basic structure is shown in [Figure 1](#).

Multiple pairs of laser emitters and receivers are attached to a motor that rotates 360° horizontally.

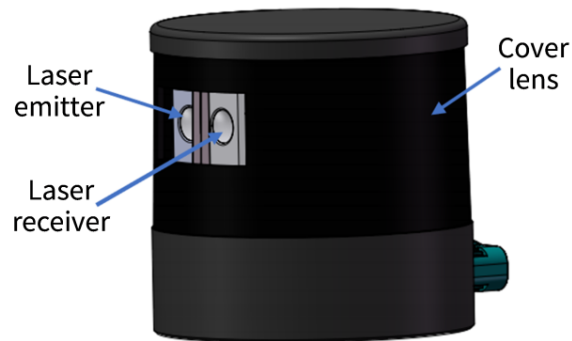

Figure 1. Partial cross-sectional diagram

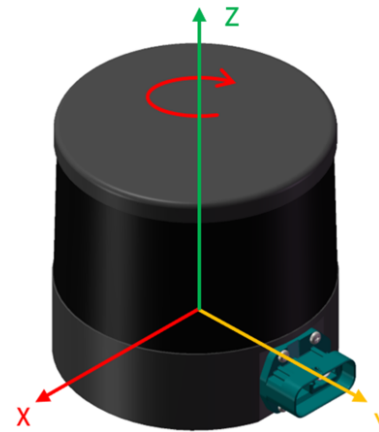

Figure 2. Coordinate system (isometric view)

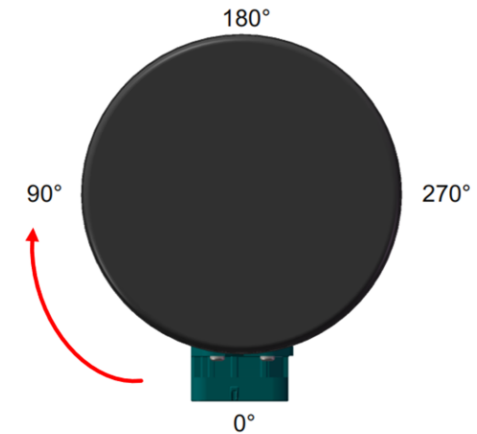

Figure 3. Lidar azimuthal position (top view)

The lidar's coordinate system is illustrated in [Figure 2](#).

- Z-axis is the axis of rotation.

The lidar's azimuthal position is defined in [Figure 3](#).

- By default, the lidar rotates clockwise in the top view. To select counterclockwise rotation, see [Section 4.2.2 Function](#).
- Y-axis corresponds to 0°.
- Each laser channel has an intrinsic azimuth offset. The horizontal center of the emitter-receiver array defines the lidar's azimuthal position.

For example, when the horizontal center passes the 90° position:

- The lidar is at the 90° position;
- The azimuth of the corresponding data block in the Point Cloud Data Packet is 90°.

1.4 Channel distribution

All channels are unevenly distributed, as illustrated in [Figure 4](#).

- Vertical resolution: see [Section 1.5 Specifications](#).
- The design values of each channel's angular position: see [Appendix A Channel distribution data](#).
- Channel number counts from 1, bottom to top.

In [Figure 5](#):

- The origin of the lidar's coordinate system is marked as a red dot. All measurements are relative to the origin.
- The center of the exit pupil is marked as a yellow dot.

Each channel has an intrinsic angle offset, both horizontally and vertically.

The elevation and azimuth of each channel's outgoing beam (relative to the center of the exit pupil) are recorded in the angle correction file of this lidar unit; see [Section A.1 Angle correction file](#).

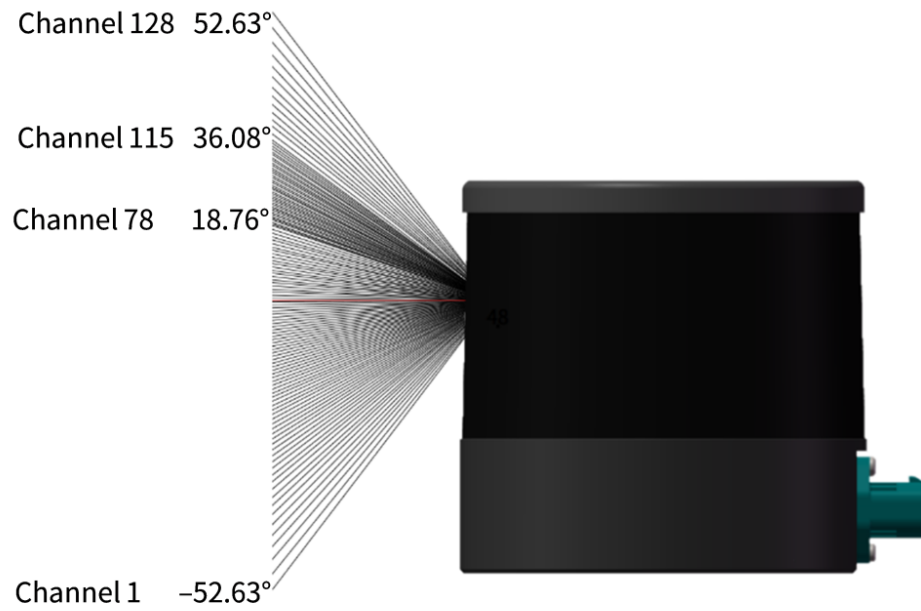

Figure 4. Channel vertical distribution

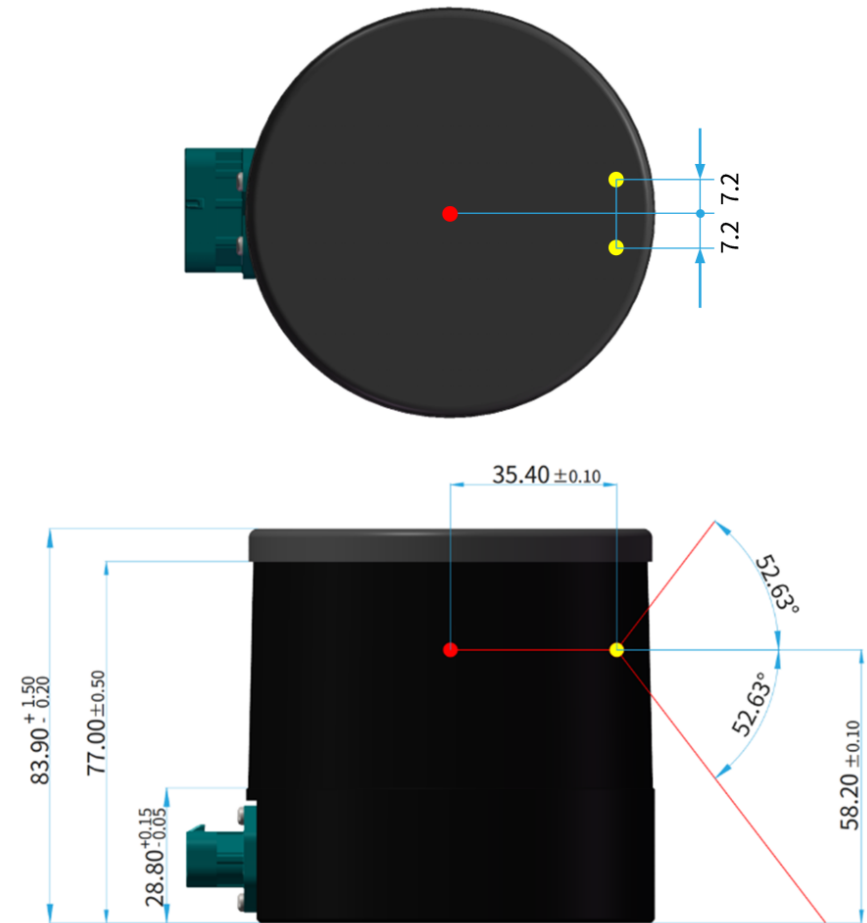

Figure 5. Laser firing position (unit: mm)

1.5 Specifications

SENSOR

Scanning method	Mechanical rotation
Number of channels	128
Instrumented range	0.05 to 50 m
Ranging capability ①	20 m (at 10% reflectivity, channels 9 to 120) 15 m (at 10% reflectivity, channels 1 to 8 and 121 to 128)
Ranging accuracy ②	±3 cm (typical)
Ranging precision ②	2 cm (typical)
Horizontal FOV	360°
Horizontal resolution	0.4° (10 Hz) (Channels 65 to 128) 0.8° (20 Hz) (Channels 65 to 128) 0.8° (10 Hz) (Channels 1 to 64) 1.6° (20 Hz) (Channels 1 to 64)
Vertical FOV	105.2° (-52.6° to +52.6°)
Vertical resolution	0.4° to 0.5° (Channels 78 to 115) 0.8° to 1.6° (other channels)
Frame rate	10 Hz, 20 Hz
Return mode	Single return: First/Second/Last/Strongest Dual return: 5 modes

MECHANICAL/ELECTRICAL/OPERATIONAL

Wavelength	940 nm
------------	--------

Laser Class	Class 1 Eye Safe
Ingress protection	IP6K7 & IP6K9K
Dimensions	Height: 83.9 mm Top/Bottom: Φ 85.9/87.0 mm
Rated voltage range ③	DC 12 to 24 V
Power consumption ④	12 W
Operating temperature ⑤	-40°C to 85°C
Storage temperature ⑤	-40°C to 95°C
Weight	900 \pm 15 g

DATA I/O

Data transmission	Automotive Ethernet, 1000BASE-T1, slave mode
Measurements	Distance, azimuth angle, and reflectivity
Valid point rate	Single Return: 864 000 points/sec Dual Return: 1 728 000 points/sec
Point cloud data rate	Single Return: 42.23 Mbps Dual Return: 84.46 Mbps
Clock Source	PTP
PTP Clock Accuracy	\leq 1 μ s (typical)
PTP Clock Drift ⑥	\leq 1 μ s/s



Specifications are subject to change. Please refer to the latest version of this manual.

Notes to specifications

① Ranging capability

- Test conditions: normal incidence, 0 to 100 klx ambient illuminance, probability of detection (PoD) > 90%, and false alarm rate (FAR) < 10E-5.
- See [Appendix A Channel distribution data](#) for the test data of each channel.

② Ranging accuracy and ranging precision

- May vary with range, temperature, and target reflectivity.
- Ranging accuracy: the average measurement error over multiple measurements taken under the same conditions
- Ranging precision: the standard deviation of multiple measurements taken under the same conditions

③ Rated voltage range

- The input voltage at the lidar's connector shall be within 9 to 32 V DC.

④ Power consumption

- Refer to [Appendix C Power supply requirements](#).
- Typical value, not including accessories such as the connection box.
- Test conditions: 85°C ambient temperature, 20 Hz frame rate.
- Refer to [Appendix C Power supply requirements](#).

⑤ Operating temperature and storage temperature

Both refer to ambient air temperature.

- During operation, the lidar's surface and internal temperatures may exceed the ambient air temperature.
- To obtain the real-time temperatures of the lidar's internal modules, refer to Get Lidar Status (0x09) in the TCP API Reference Manual.

⑥ PTP Clock Drift

Defined as the drift at a constant temperature after the lidar (slave clock) loses connection to the PTP master.

2 Setup

Before operating the lidar, strip away the protective cover on the cover lens.



The information in this section may be different for customized models. The mechanical drawings and data exclusively provided for customized models shall prevail.

2.1 Mechanical installation

2.1.1 Exterior dimensions

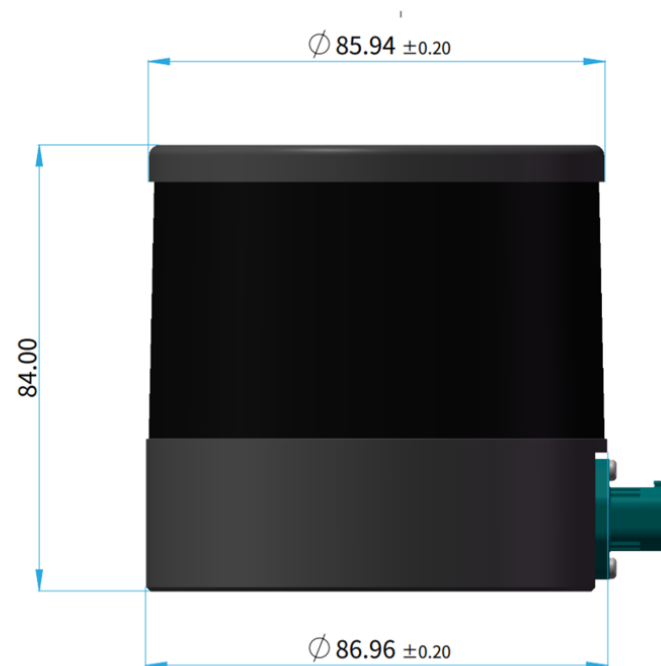

Figure 6. Left side view (unit: mm)

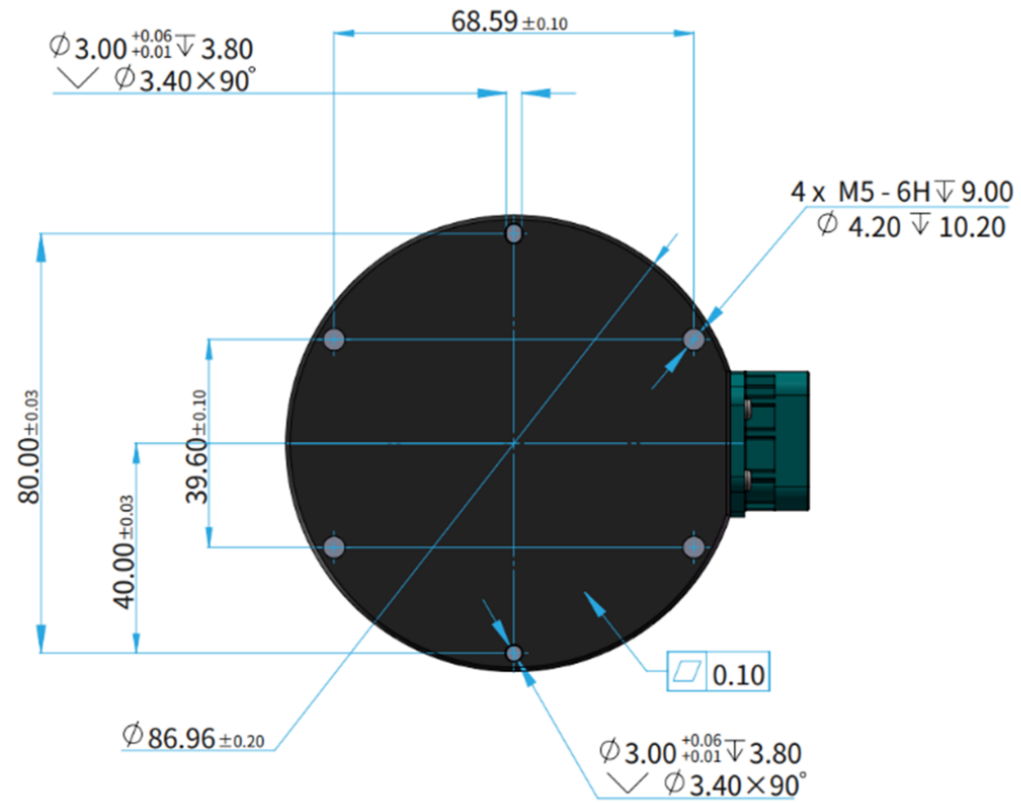

Figure 7. Bottom view (unit: mm)

2.1.2 Recommended installation

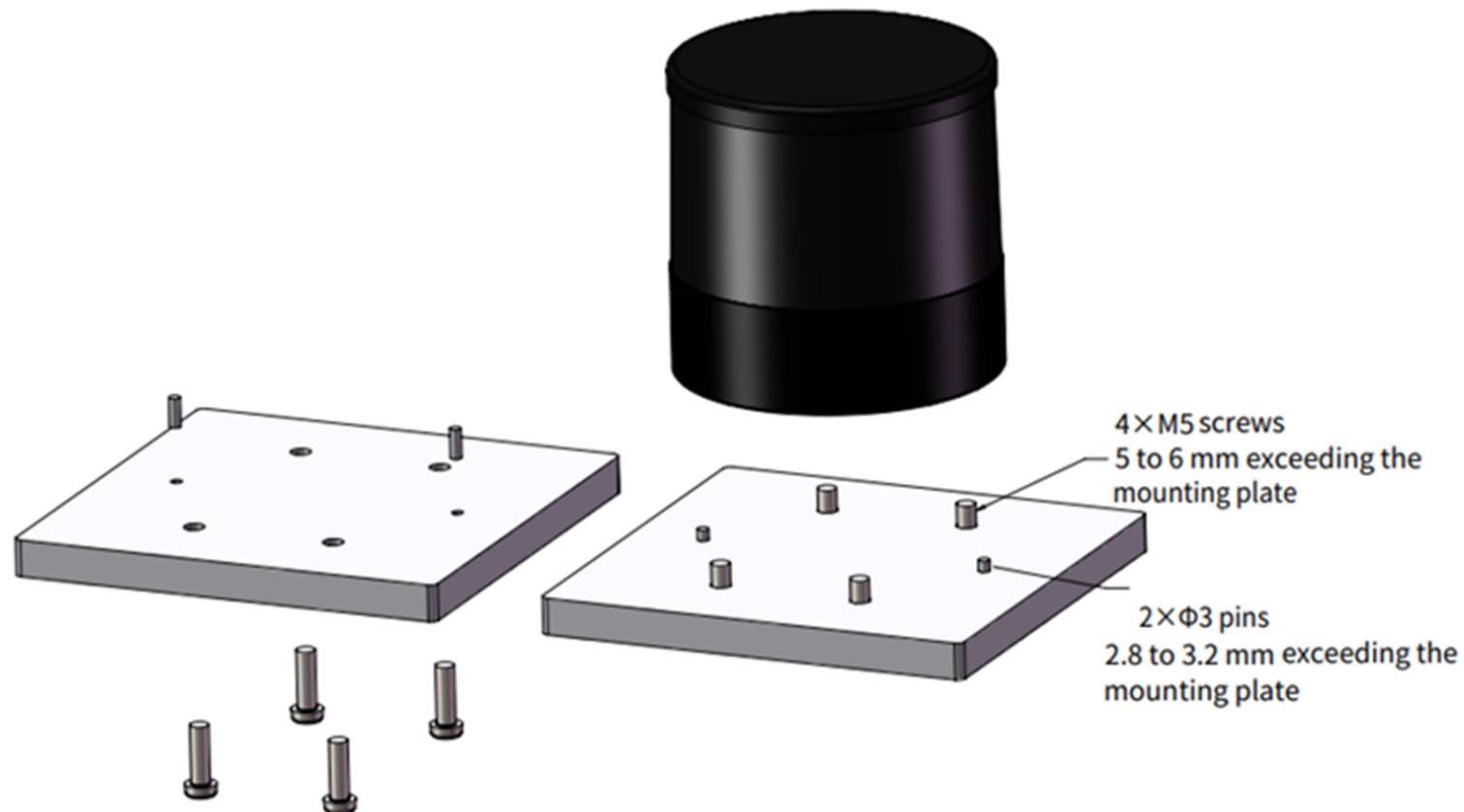

Figure 8. Recommended installation

To maximize data integrity and ESD protection, chassis grounding is strongly recommended:



- Mount the lidar on a properly grounded metal bracket.
- Ensure reliable electrical continuity between the lidar enclosure, the mounting screws, and the bracket.

In installations where chassis grounding is impractical or impossible (e.g., battery-powered or airborne platforms), high-quality shielded

twisted pair (STP) Ethernet cables with properly grounded connectors is a recommended alternative.

2.1.3 Notes on screw installation



Strictly follow the screw specifications and installation requirements in [Figure 8](#).

Screw type

SEMS screws (with pre-attached flat washers and lock washers) are recommended. Property class should be at least 4.8.

Threadlocker

Before fastening a screw, apply 1 or 2 dots of threadlocker in the thread fit area. LOCTITE® 263 Threadlocker is recommended. To ensure curing it in place, wait for at least 12 hours before operating the lidar.

Screw torque

The base material of the threaded holes is aluminum alloy, not steel. Refer to the following table for the appropriate screw torque.

Thread size	Recommended screw torque
M2	0.2 to 0.3 Nm
M3	0.5 to 0.6 Nm
M4	1 to 1.5 Nm
M5	2 to 2.5 Nm
M6	3.5 to 4 Nm

Thread service life

25 times. (Each screwing counts as one time, so as each unscrewing.)

2.2 Electrical interface

Rosenberger Part Number: E6S14M-40MT5-Z (male socket, on the lidar), E6K14M-1CAZ5-Z (female plug, connected to the lidar)



May be different for customized models. The information provided separately from this manual shall prevail.

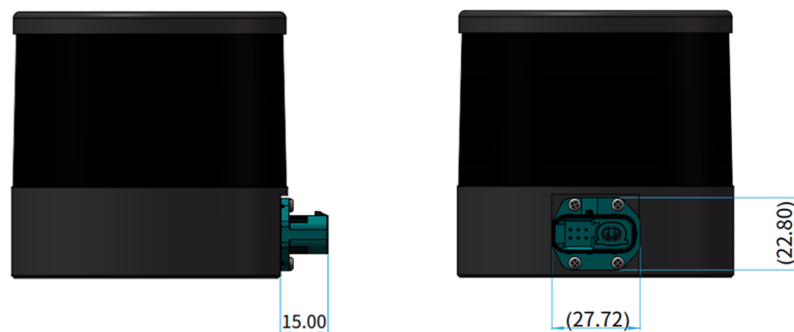

Figure 9. Connector dimensions (unit: mm)

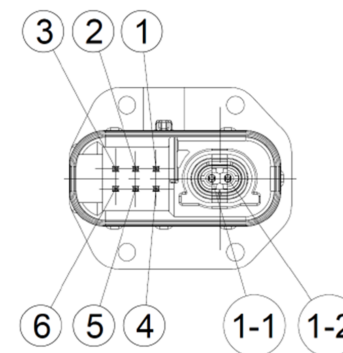

Figure 10. Connector front view (unit: mm)

2.2.1 Pin description

No.	Signal	Voltage	No.	Signal	Voltage
1	VIN	12 to 24 V	5	Reserved	0 to 3.3 V
2	Reserved	0 to 3.3 V	6	GND	0 V
3	Reserved	0 to 3.3 V	1-1	Ethernet_TRX+	-1 to 1 V
4	NC	-	1-2	Ethernet_TRX-	-1 to 1 V

2.2.2 Connector use



- Before connection, check the pins on the socket and the holes on the plug. In case of bent pins or damaged holes, stop using the connector and contact technical support.
- To prevent breakdowns, turn off the power source before connection and disconnection.
- Do NOT attempt to force open a connection by pulling on the cables or by twisting the connectors in any way. Doing so can loosen the connectors' shells, or even damage the contacts.
- If the connector's shell is accidentally pulled off, stop using the connector and contact Hesai technical support. Do NOT attempt to assemble the connector's shell and cable collet; do NOT connect a connector without its shell. Doing so may damage the lidar's circuits.
- For further troubleshooting, please contact Hesai technical support or obtain work instructions from the connector manufacturer.
- The connector is designed to withstand at least **10** mating cycles; exceeding this number may increase the risk of connector damage.

Connection	<ol style="list-style-type: none"> 1. Turn off the power source. 2. Make sure the plug's red CPA is on the same side as the socket's locking nose. 3. Push the plug straight into the socket until you feel and hear a click. 4. Push the red CPA towards the socket until you feel and hear a click.
Disconnection	<ol style="list-style-type: none"> 1. Turn off the power source. 2. Pull the red CPA away from the socket until you feel and hear a click. 3. Depress the water blue locking latch; then pull the plug from the socket.

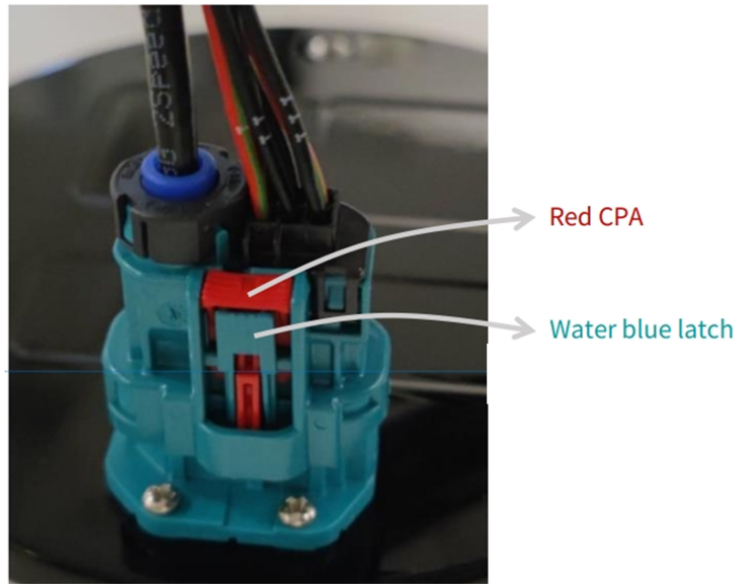

2.2.3 Cables (Ethernet)

Outer diameter (OD) = 4.10 ± 0.20 mm

Minimum bend radius:

- Single: $3 \times OD$
- Multiple ($\leq 10x$): ≥ 40 mm
- Multiple ($> 10x$): $10 \times OD$

2.3 Connection box (optional)

Users may connect the lidar with or without a connection box.

The connection box has a power port. It also has a standard Ethernet port, converting automotive 1000BASE-T1 to 1000BASE-T typical Ethernet.

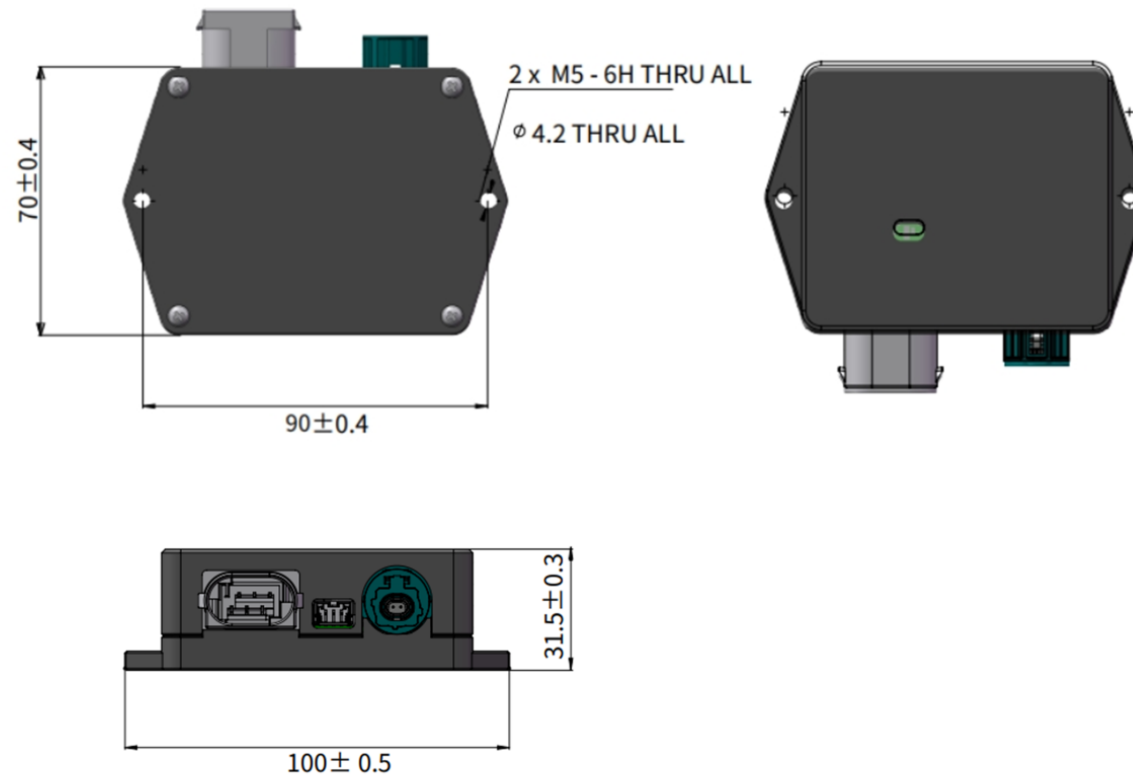

Figure 11. Connection box (unit: mm)



One cable's head cannot connect to another cable's tail, so each lidar can only use one cable.

2.3.1 Ports

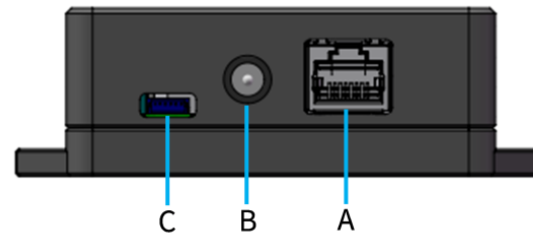

Figure 12. Connection box (front view)

Port	Port name	Description
A	Standard Ethernet port	RJ45, 1000 Mbps Ethernet
B	Power port	Connects to a PJ-057AH DC power adaptor
C	Reserved port	Do NOT connect this port to external signals.

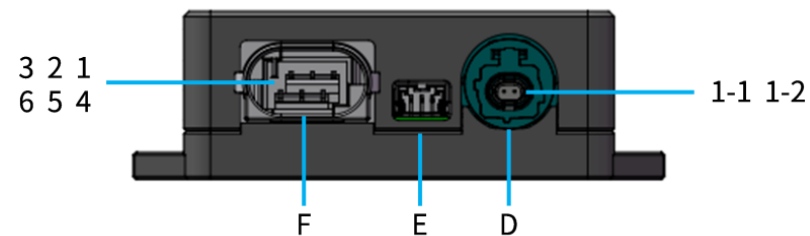

Figure 13. Connection box (back view)

Port	Port name	Description
D	Connection to lidar	See Section 2.2.1 Pin description . Connector (socket): Rosenberger, E6S24A-40MT5-Z Recommended wire connector (plug): Rosenberger, E6K14A-1CAZ5-Z

Port	Port name	Description
E	Reserved port	Do NOT connect this port to external signals.
F	Connection to lidar	See Section 2.2.1 Pin description . Connector (socket): TE Connectivity, 1241637-1 Recommended wire connector (plug): TE Connectivity, 1-967616-1

2.3.2 Connection

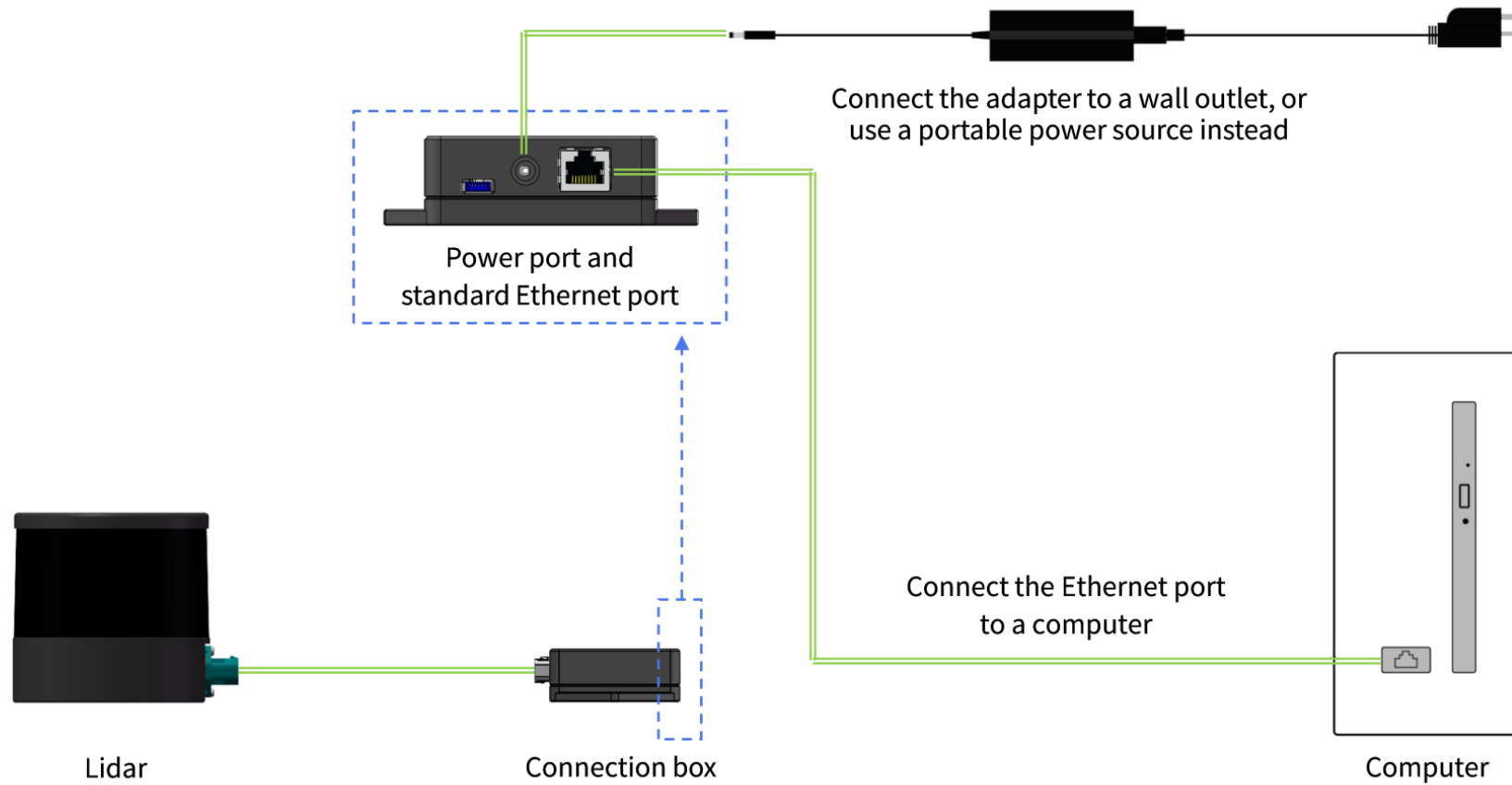

Figure 14. Connection with PTP (software simulation)

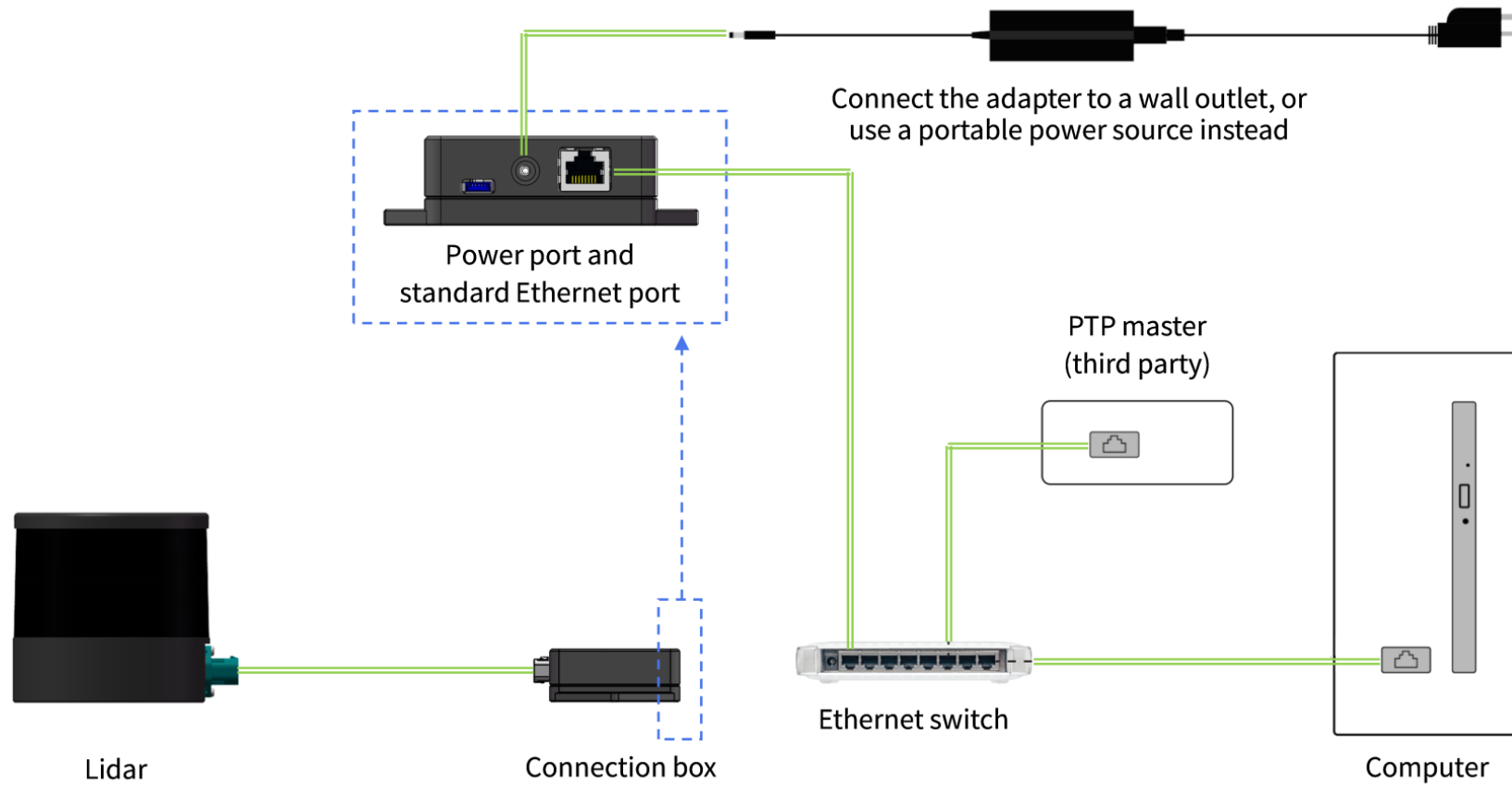

Figure 15. Connection with PTP (hardware device)

2.4 Network settings on the host computer

The lidar has no power switch. It starts transmitting data when both of these conditions are met:

- The lidar is connected to power.
- The lidar is connected to a host computer via Ethernet.

To analyze point cloud data, configure the network parameters of the host computer:

Network parameters	Value	Description
IP address	192.168.1.X	X can be selected from 2 to 200 and from 202 to 254.
Subnet mask	255.255.255.0	-

2.4.1 In Windows

1. [**Control Panel**] > [**Network and Internet**] > [**Network and Sharing Center**] > [**Change adapter settings**].
2. Right-click [**Ethernet**] or [**Ethernet X**] which shows Ethernet connection (with no red cross at the bottom left of the icon) > Select [**Properties**].

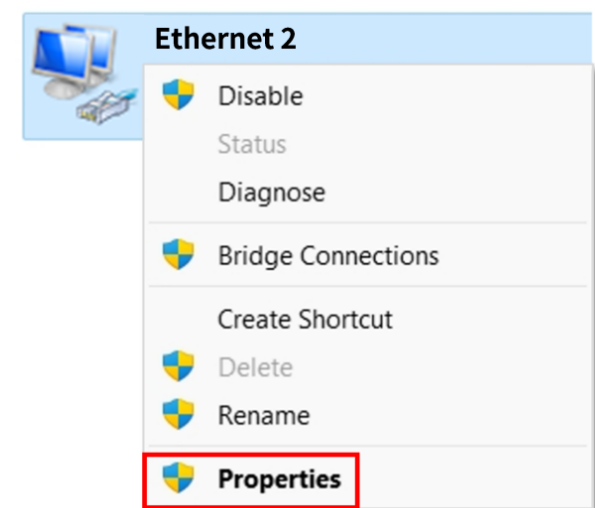
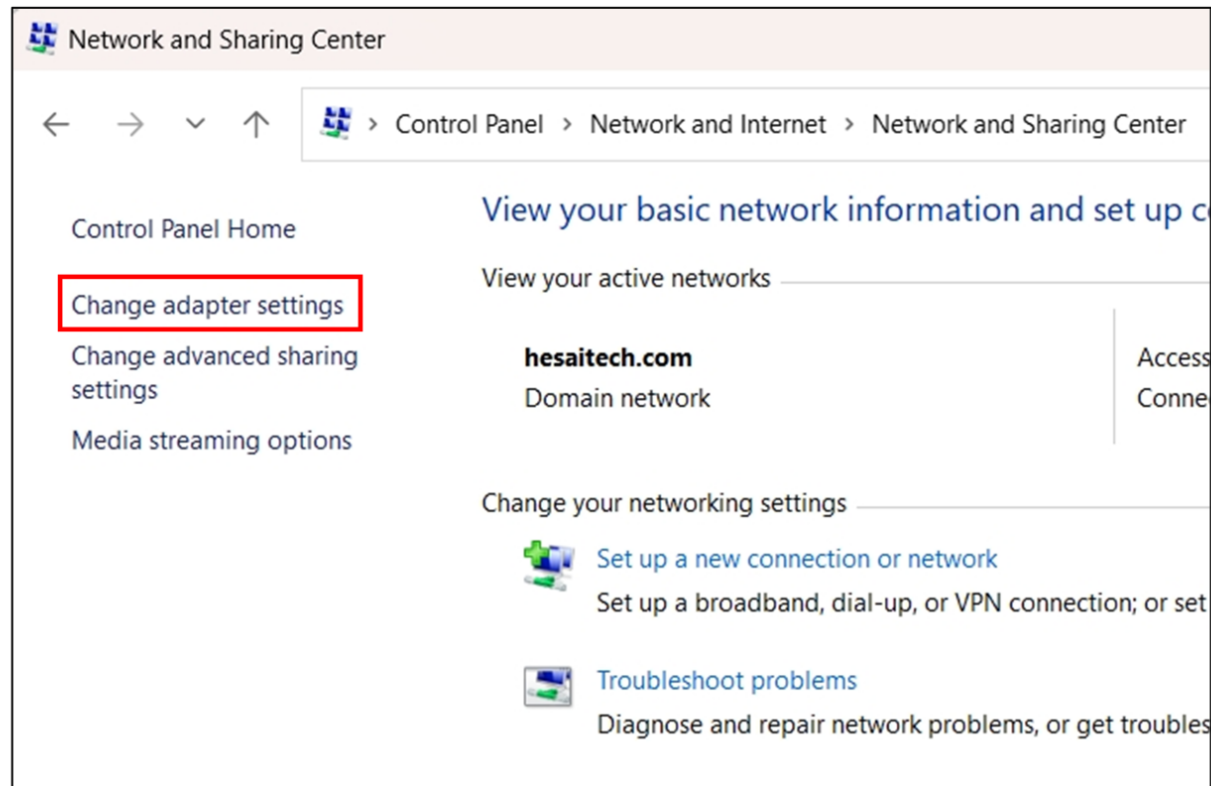

3. Double-click [**Internet Protocol Version 4 (TCP/IPv4)**].
4. Select [**Use the following IP addresses**] > Input the host computers's IP address and subnet mask.

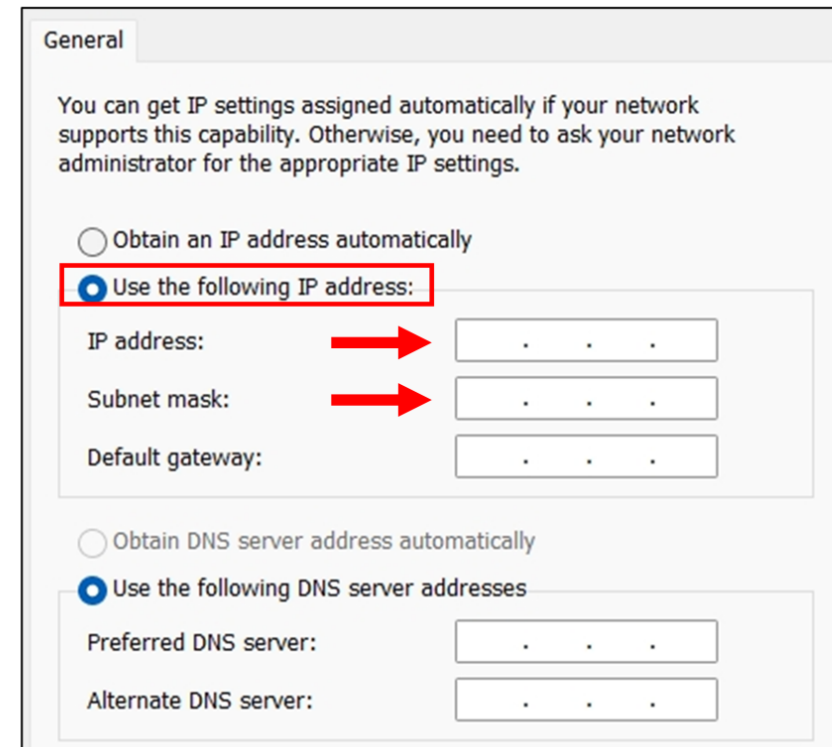
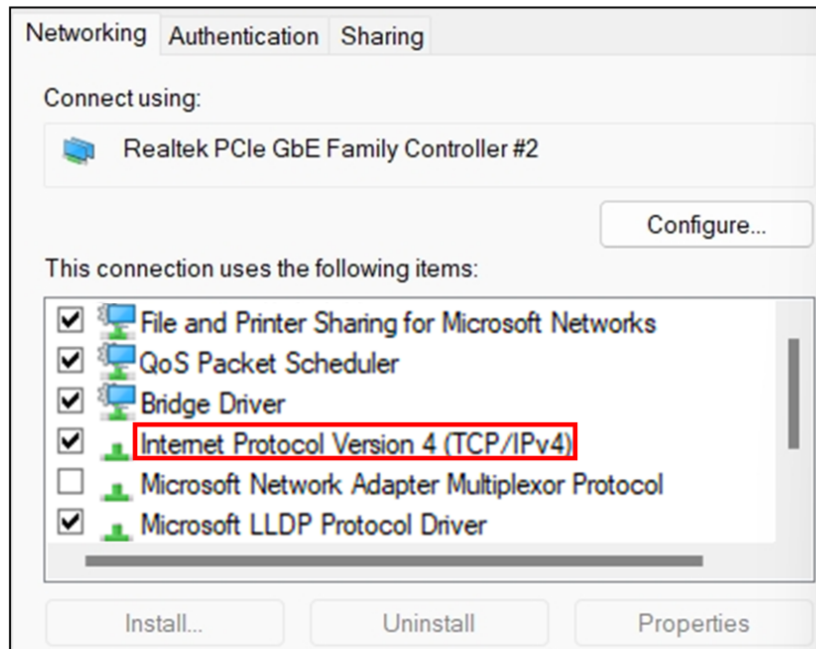

Ping command can be used to check the connection:



1. Press Win + R to open the Run dialog box.
2. Enter "cmd" and click [**OK**] to open the Command Prompt.
3. Enter "ping 192.168.1.201" and check the output.

2.4.2 In Ubuntu

1. Find the host computer's network interface name.

Method 1

- a. Open **Settings — Network**.
- b. Look for the interface whose status is "Connected".
The name in parentheses after "Ethernet" is the network interface name.



Method 2

- a. Open a terminal and run this command:

```
ifconfig
```

- b. Look for the interface with non-zero RX packets and bytes.
(In the example below, **enp5s0** shows non-zero Rx packets and bytes, indicating active data transmission.)

```
> ifconfig
docker0: flags=4099<UP,BROADCAST,MULTICAST> mtu 1500
  inet [REDACTED] netmask [REDACTED] broadcast [REDACTED]
  ether [REDACTED] txqueuelen 0 (Ethernet)
  RX packets 0 bytes 0 (0.0 B)
  RX errors 0 dropped 0 overruns 0 frame 0
  TX packets 0 bytes 0 (0.0 B)
  TX errors 0 dropped 0 overruns 0 carrier 0 collisions 0

enp2s0f0: flags=4099<UP,BROADCAST,MULTICAST> mtu 1500
  ether [REDACTED] txqueuelen 1000 (Ethernet)
  RX packets 0 bytes 0 (0.0 B)
  RX errors 0 dropped 0 overruns 0 frame 0
  TX packets 0 bytes 0 (0.0 B)
  TX errors 0 dropped 0 overruns 0 carrier 0 collisions 0

enp5s0: flags=4099<UP,BROADCAST,MULTICAST> mtu 1500
  ether [REDACTED] txqueuelen 1000 (Ethernet)
  RX packets 267706980 bytes 300970909734 (300.9 GB)
  RX errors 0 dropped 0 overruns 0 frame 0
  TX packets 3184 bytes 590575 (590.5 KB)
  TX errors 0 dropped 0 overruns 0 carrier 0 collisions 0
```

2. Run this command in the terminal:

```
sudo ifconfig ${interface_name} ${ip_addr}
```

- Replace `${interface_name}` with the host computer's network interface name.
- Replace `${ip_addr}` with the host computer's IP address.

2.5 Tools



- The following tools are supported by most models. Contact Hesai technical support to confirm applicability.
- For a customized model or an early prototype, contact Hesai technical support to confirm applicability.

Tool	Purpose	Where to find it
PandarView 2 (point cloud visualization software)	To record and display point cloud data.	Public versions (for selected models only): https://www.hesaitech.com/downloads/
LidarUtilities (software for host computers)	To set parameters, check device info and status, or upgrade firmware and software.	Contact Hesai technical support for details.
API		Contact Hesai technical support to confirm the applicable API type for this model (HTTP, PTC, or serial communication API) and obtain the corresponding technical documentation.
Software development kits (SDKs) and ROS drivers	To assist development.	Public versions (for selected models only): https://github.com/HesaiTechnology
Web control	To set parameters, check device info and status, or upgrade firmware and software.	If this model supports web control, see the "Web Control" section of this manual.

3 Data structure

Unless otherwise specified, all the multi-byte fields are unsigned values transmitted in little-endian format.

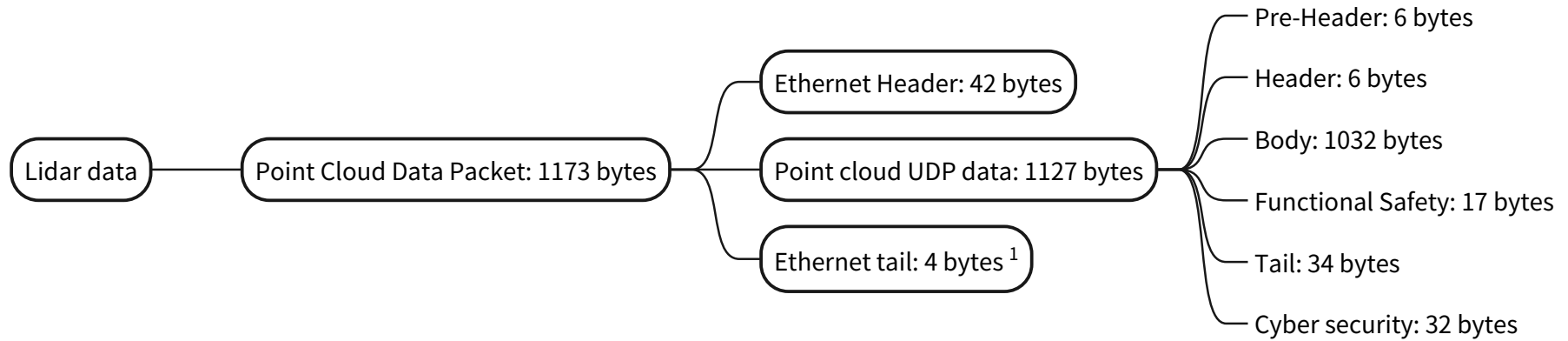

1. Network monitoring software (such as WireShark) usually does not display the **Ethernet tail** (4 bytes).

Figure 16. Data structure

3.1 Point cloud data packet

Before receiving Point Cloud Data Packets, please perform [Network settings on the host computer](#).

3.1.1 Ethernet Header

Point Cloud Data Packet: Ethernet Header

Field	Byte(s)	Description
Ethernet II MAC	12	Destination MAC: xx:xx:xx:xx:xx:xx (FF:FF:FF:FF:FF:FF for broadcast) Source MAC: xx:xx:xx:xx:xx:xx
Ethernet Data Packet Type	2	0x08, 0x00
Internet Protocol	20	Protocol parameters
UDP Port Number	4	Source port (default: 10000) Destination port (default: 2368)
UDP Length	2	Eight bytes more than point cloud UDP data (see Figure 16. Data structure).
UDP Checksum	2	Checksum of the Ethernet Header

3.1.2 Point cloud UDP data

Pre-Header

Field	Byte(s)	Description
Start of Packet	1	0xEE
Start of Packet	1	0xFF
Protocol Version Major	1	Main class of the point cloud UDP packet structure Current value: 0x03
Protocol Version Minor	1	Subclass of the point cloud UDP packet structure Current value: 0x02
Reserved	2	-

Header

Field	Byte(s)	Description																								
Channel Num	1	Fixed: 0x80 (128)																								
Block Num	1	0x02 (2 blocks per packet)																								
First Block Return	1	Reserved																								
Dis Unit	1	Unit of the Distance field in Section 3.1.2.3 Body . Default: 0x04 (4 mm)																								
Return Num	1	Number of returns that each channel generates 0x01 (1) 0x02 (2)																								
Flags	1	Each bit indicates whether this data packet contains certain information. <table border="1" data-bbox="757 756 2074 1227"> <thead> <tr> <th>Bit</th> <th colspan="2">Value</th> </tr> </thead> <tbody> <tr> <td>[7] Reserved</td> <td>-</td> <td>-</td> </tr> <tr> <td>[6] Channel Customization</td> <td>1 — Selected channels</td> <td>0 — All channels (fixed)</td> </tr> <tr> <td>[5:4] Reserved</td> <td>-</td> <td>-</td> </tr> <tr> <td>[3] Digital Signature</td> <td>1 — YES</td> <td>0 — NO</td> </tr> <tr> <td>[2] Functional Safety</td> <td>1 — YES (fixed)</td> <td>0 — NO</td> </tr> <tr> <td>[1] Reserved</td> <td>-</td> <td>-</td> </tr> <tr> <td>[0] UDP Sequence</td> <td>1 — YES (fixed)</td> <td>0 — NO</td> </tr> </tbody> </table>	Bit	Value		[7] Reserved	-	-	[6] Channel Customization	1 — Selected channels	0 — All channels (fixed)	[5:4] Reserved	-	-	[3] Digital Signature	1 — YES	0 — NO	[2] Functional Safety	1 — YES (fixed)	0 — NO	[1] Reserved	-	-	[0] UDP Sequence	1 — YES (fixed)	0 — NO
Bit	Value																									
[7] Reserved	-	-																								
[6] Channel Customization	1 — Selected channels	0 — All channels (fixed)																								
[5:4] Reserved	-	-																								
[3] Digital Signature	1 — YES	0 — NO																								
[2] Functional Safety	1 — YES (fixed)	0 — NO																								
[1] Reserved	-	-																								
[0] UDP Sequence	1 — YES (fixed)	0 — NO																								

Body**Return mode**

Four single-return modes and five dual-return modes are available, indicated by the **Return Mode** field in [Section 3.1.2.5 Tail](#).

In single-return mode: the measurements from each round of firing are stored in one block.



In dual-return mode:

- * The measurements from each round of firing are stored in the two blocks of one packet (see the table below);
- * Azimuth changes every packet;
- * Firing Sequence changes every packet, indicated by the **Mode Flag** field in [Section 3.1.2.5 Tail](#).

Return mode	Odd-numbered block	Even-numbered block	Note
Last and Strongest	Last return	Strongest return	If the last return is also the strongest, then the even-numbered block stores the second strongest return.
First and Last	First return	Last return	If there is only one return, then the two blocks store the same data.
First and Strongest	First return	Strongest return	If the first return is also the strongest, then the even-numbered block stores the second strongest return.
Strongest and Second Strongest	Strongest return	Second Strongest return	If there is only one return, then the two blocks store the same data.
First and Second	First return	Second return	If there is only one return, then the two blocks store the same data.

Field	Byte(s)	Description
Azimuth 1	2	For Block 1: current reference angle of the azimuth Unit: 0.01°
Block 1	512	Measurements of each channel (starting from Channel 1) Refer to Each channel in the block .
Azimuth 2	2	For Block 2: current reference angle of the azimuth
Block 2	512	Measurements of each channel
CRC 1	4	CRC-32/MPEG-2 checksum of the Body <div style="border: 1px dashed gray; padding: 5px; margin-top: 10px;">  For more on the CRC-32/MPEG-2 computation algorithm, refer to: https://www.mathworks.com/matlabcentral/fileexchange/72226-crc-32-mpeg-2-computation-algorithm </div>

Each channel in the block

Field	Byte(s)	Description												
Channel 1	4	Measurements of Channel 1												
		<table border="1"> <thead> <tr> <th>Field</th> <th>Byte(s)</th> <th>Description</th> </tr> </thead> <tbody> <tr> <td>Distance</td> <td>2</td> <td>Object distance = Distance × Dis Unit <div style="border: 1px dashed gray; padding: 5px; margin-top: 5px;">  Dis Unit is specified in Section 3.1.2.2 Header. </div> </td> </tr> <tr> <td>Reflectivity</td> <td>1</td> <td>Reflectivity Value = Reflectivity Field × 1% Range: 0 to 255</td> </tr> <tr> <td>Reserved</td> <td>1</td> <td>-</td> </tr> </tbody> </table>	Field	Byte(s)	Description	Distance	2	Object distance = Distance × Dis Unit <div style="border: 1px dashed gray; padding: 5px; margin-top: 5px;">  Dis Unit is specified in Section 3.1.2.2 Header. </div>	Reflectivity	1	Reflectivity Value = Reflectivity Field × 1% Range: 0 to 255	Reserved	1	-
		Field	Byte(s)	Description										
		Distance	2	Object distance = Distance × Dis Unit <div style="border: 1px dashed gray; padding: 5px; margin-top: 5px;">  Dis Unit is specified in Section 3.1.2.2 Header. </div>										
Reflectivity	1	Reflectivity Value = Reflectivity Field × 1% Range: 0 to 255												
Reserved	1	-												
Reflectivity	1	Reflectivity Value = Reflectivity Field × 1% Range: 0 to 255												
Reserved	1	-												
Channel 2	4	Measurements of Channel 2												

Field	Byte(s)	Description
Channel 3	4	Measurements of Channel 3
...
Channel 128	4	Measurements of Channel 128



If a channel does not fire in the current Firing Sequence, its corresponding four bytes are filled with 0.

Definition of the distance field

Up-Close Blockage Detection = OFF	Description
Distance ≥ 12	Object distance = Distance \times Dis Unit ≥ 0.048 m Dis Unit : see Section 3.1.2.2 Header .
Distance = 0	No laser emission.
Up-Close Blockage Detection = ON	Description
Distance ≥ 12	Object distance = Distance \times Dis Unit ≥ 0.048 m Dis Unit : see Section 3.1.2.2 Header .
Distance = 0	No laser emission.
Distance = 1	Either no return signal is received, or return signal is received but rejected. Thus, no valid point cloud output. Common reasons for return signal rejection: <ul style="list-style-type: none"> • The signal is generated by another lidar unit. • Object distance exceeds the upper limit of the lidar's measurement range. • Pulse intensity is below the threshold. • The signal is filtered out. See Retro Multi-Reflection Filtering in Section 4.2 Settings.



Users can enable or disable Up-Close Blockage Detection (see [Section 4.2 Settings](#)).

Functional Safety

Field	Byte(s)	Description
FS Version	1	Version number of the functional safety module (currently 0x01)
Lidar State	1	[7:5] is the lidar's current state. d-0 (b-000) Initialization d-1 (b-001) Normal d-2 (b-010) Warning d-3 (b-011) Performance Degradation (not yet supported) d-4 (b-100) Shutdown or Output Untrusted
Fault Code Type		[4:3] is the type of fault code in this data packet. b-00 No fault b-01 Current fault b-10 Past fault (not yet supported)
Rolling Counter (for Fault Messages)		[2:0] indicates whether the fault reporting system gets stuck. Starting from 0, the rolling counter increments by 1 every 5 ms.
Total Fault Code Num	1	[7:4] is the total number of fault codes in the buffer queue.
Fault Code ID		[3:0] is the sequence number of the current fault code in the buffer queue, starting from 1.
Fault Code	2	The fault code sent by this data packet.
Reserved	8	-
CRC 2	4	CRC-32/MPEG-2 checksum of Functional Safety (from the Lidar State field to the Reserved field).



The Lidar States and fault codes are described in the *Safety Manual*. Please contact Hesai technical support for more information.

Tail

Field	Byte(s)	Description
Reserved	5	-
Mode Flag	1	<p>[7:1] is reserved.</p> <p>[0] indicates the Firing Sequence used in Block 1:</p> <p>1 – Firing Sequence 1</p> <p>0 – Firing Sequence 2</p> <ul style="list-style-type: none"> In single-return mode: [0] = 1 (fixed). Blocks 1 and 2 use Firing Sequences 1 and 2, respectively. In dual-return mode: When [0] = 1, Blocks 1 and 2 use Firing Sequence 1, and for the next packet, [0] = 0. When [0] = 0, Blocks 1 and 2 use Firing Sequence 2, and for the next packet, [0] = 1. <p>Firing Sequences are defined in Section B.5 Firing time offset of each channel.</p>
Reserved	6	-
Return Mode	1	<p>0x33 – First Return</p> <p>0x34 – Second Return</p> <p>0x37 – Strongest Return</p> <p>0x38 – Last Return</p> <p>0x39 – Last, Strongest Return</p> <p>0x3B – First, Last Return (default)</p> <p>0x3C – First, Strongest Return</p> <p>0x3E – Strongest, Second Strongest Return</p> <p>0x3A – First, Second Return</p>
Motor Speed	2	<p>Unit: RPM</p> <div style="border: 1px dashed gray; border-radius: 10px; padding: 5px; margin-top: 10px;">  Spin rate of the motor (RPM) = frame rate (Hz) × 60 </div>

Field	Byte(s)	Description														
Date & Time	6	Whole second part of the Coordinated Universal Time (UTC) of this data packet														
		<table border="1"> <thead> <tr> <th>Each byte</th> <th>Range (decimal)</th> </tr> </thead> <tbody> <tr> <td>Year (current year minus 1900)</td> <td>≥ 70</td> </tr> <tr> <td>Month</td> <td>1 to 12</td> </tr> <tr> <td>Day</td> <td>1 to 31</td> </tr> <tr> <td>Hour</td> <td>0 to 23</td> </tr> <tr> <td>Minute</td> <td>0 to 59</td> </tr> <tr> <td>Second</td> <td>0 to 59</td> </tr> </tbody> </table>	Each byte	Range (decimal)	Year (current year minus 1900)	≥ 70	Month	1 to 12	Day	1 to 31	Hour	0 to 23	Minute	0 to 59	Second	0 to 59
		Each byte	Range (decimal)													
		Year (current year minus 1900)	≥ 70													
		Month	1 to 12													
		Day	1 to 31													
		Hour	0 to 23													
		Minute	0 to 59													
Second	0 to 59															
UTC Fractional Seconds	4	<p>The microsecond part of the absolute time of this data packet</p> <p>Unit: μs</p> <p>Range: 0 to 999 999 μs (1 s)</p> <div style="border: 1px dashed gray; padding: 5px; margin-top: 10px;">  The absolute time of a Point Cloud Data Packet is defined in Appendix B Absolute time of point cloud data. </div>														
Factory Information	1	Fixed: 0x42														
UDP Sequence	4	Sequence number of this data packet Range: 0 to 0xFF FF FF FF														
CRC 3	4	CRC-32/MPEG-2 checksum of the Tail														

Cyber security

Field	Byte(s)	Description
Signature	32	<p>Point cloud signature Calculated using Point cloud UDP data (from Pre-Header to Tail) Algorithm: HMAC-SHA-256 (256 bits)</p> <div data-bbox="779 379 2072 475" style="border: 1px dashed gray; padding: 5px;"><p> This field is all zeros by default. After users specify a Shared Secret Key and start a session, this field will output point cloud signature. Refer to Section 4.8.3 Point cloud signature.</p></div>

3.1.3 Ethernet tail

Field	Byte(s)	Description
FCS	4	Frame check sequence

3.1.4 Point cloud data analysis method

Take **Channel 66** in **Block 2** as an example.

Analyze the vertical angle of a data point

The designed vertical angle of **Channel 66** is 8.728° , according to [Appendix A Channel distribution data](#).



- The accurate vertical angles are recorded in the angle correction file of this lidar; see [Section 1.4 Channel distribution](#)
- 0° is the horizontal direction. The upward direction is defined as positive; see [Figure 4. Channel vertical distribution](#).
- Channel number counts from 1, bottom to top.

Analyze the horizontal angle of a data point



Y-axis is the 0° position. The clockwise direction (in the top view) is defined as positive; see [Figure 3. Lidar azimuthal position \(top view\)](#).

$$\text{Horizontal angle} = \textcircled{1} + \textcircled{2}$$

①: Angular position of current block (see Appendix II for definition)

②: Firing time angular offset of the current firing channel

$$\textcircled{1} = \textcircled{3} + \textcircled{4}$$

③ Rotor reference angle during the current round of firing

In the **Azimuth** field of Block 2.

④ Horizontal angle offset of the current firing channel

The designed offset for Channel 66 is 5.962° , according to [Appendix A Channel distribution data](#).



The accurate azimuth offset is recorded in this lidar unit's angle correction file; see [Appendix A Channel distribution data](#).

$$\textcircled{2} = \textcircled{5} \times \textcircled{6}$$

- ⑤ Firing time offset of the current firing channel
 - Use the **Mode Flag** and **Return Mode** in [Section 3.1.2.5 Tail](#) to get the Firing Sequence of block 2.
 - Refer to [Appendix B Absolute time of point cloud data](#).
 - For Firing Sequence 1, the firing time offset for **Channel 66** is 77.488 μ s.
 - For Firing Sequence 2, the firing time offset for **Channel 66** is 76.632 μ s.
- ⑥ Spin rate of the motor
See [Section 4.1 Home](#).

Analyze the distance of a data point

Use the **Distance of Block 2: Channel 66** in [Section 3.1.2.3 Body](#).

Draw the data point in a spherical or rectangular coordinate system

In a spherical coordinate system, the vertical and horizontal angles are defined in the figure below.

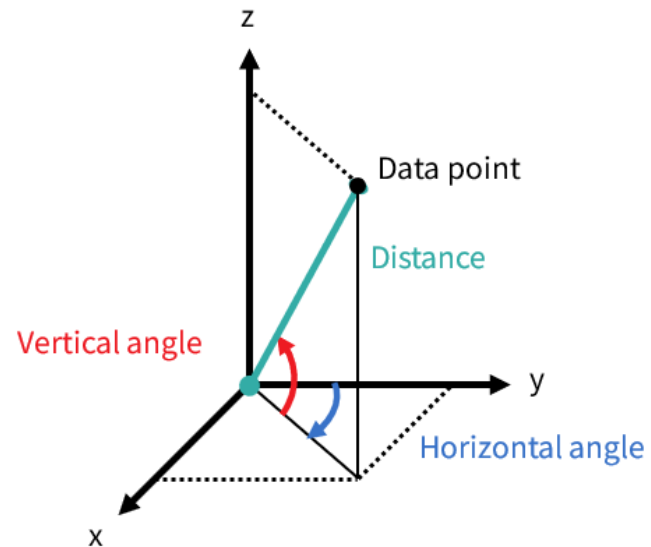

Obtain the real-time point cloud data by analyzing and drawing every data point in each frame

4 Web Control

Web Control is used for setting parameters, checking device info, and upgrading.

To access Web Control, follow the steps below:

1. Connect the lidar to your PC using an Ethernet cable.
2. Complete [Section 2.4 Network settings on the host computer](#).
3. Enter this URL in your web browser: 192.168.1.201.



Google Chrome and Mozilla Firefox are recommended.

4.1 Home

Status	
Spin Rate	600 RPM
PTP	Free Run
Device Info	Device Log
Model	QT128C2X
P/N	QT128C2X-E01
S/N	QTXXXXXXXXXXXXXXXX
MAC Address	XX:XX:XX:XX:XX:XX
Software Version	3.1.66
Sensor Firmware Version	3.1.36
Controller Firmware Version	3.1.40

Parameter	Description	
Spin Rate	Spin rate of the motor (RPM) = frame rate (Hz) × 60	
PTP	PTP status	
	Free Run	No PTP master is selected.
	Tracking	Attempting to sync with the selected PTP master, but the absolute offset exceeds the user-specified limit in Section 4.2.3 Time sync .
	Locked	The absolute offset is within the user-specified limit.
	Frozen (Holdover)	The lidar has lost connection to the PTP master and is attempting to recover it. Meanwhile, lidar time will drift from the last synchronized time.

4.2 Settings

		Reset All Settings
Control IP		
IPv4 Address		192.168.1.201
IPv4 Mask		255.255.255.0
IPv4 Gateway		192.168.1.1
Settings		
Destination IP		255.255.255.255
Lidar Destination Port		2368
Fault Message Destination Port		2368
Spin Rate		600 RPM
Return Mode		First and Last Return
Sync Angle	✓	0
Trigger Method		Time Based
Clock Source		PTP
Profile		1588v2
PTP Network Transport		UDP/IP
PTP Domain Number		0
PTP logAnnounceInterval		1
PTP logSyncInterval		1
PTP logMinDelayReqInterval		0

Time Offset for Lidar Lock	1
Up-Close Blockage Detection	OFF
Retro Multi-Reflection Filtering	OFF
Rotation Direction	Clockwise
Standby Mode	In Operation/Standby
Save	



Button	Description
Reset All Settings	Reset all the configurable parameters to factory defaults, including: <ul style="list-style-type: none"> • Section 4.2 Settings. • Section 4.3 Azimuth FOV.
Save	Save and execute all the settings on this page. Exception: Standby Mode takes effect immediately without having to click [Save].

4.2.1 Network

Parameter	Options	Description	
Destination IP	<ul style="list-style-type: none"> Any except 0.0.0.0, 127.0.0.1, and the lidar's IPv4 address Default: 255.255.255.255 	Communication mode	Destination IP
		Broadcast (default)	255.255.255.255
		Multicast	User-defined
		Unicast	Same as the PC's IPv4 address
Lidar Destination Port	Default: 2368	Destination port of point cloud data and Web Control (HTTP API)	
Fault Message Destination Port	Default: 2368	Destination port of fault messages	

4.2.2 Function

Parameter	Options	Description
Spin Rate	600 RPM (default) 1200 RPM	Spin rate of the motor <ul style="list-style-type: none"> • The accurate spin rate is shown in Point Cloud Data Packets (see the Motor Speed field in Section 3.1.2.5 Tail). • The set spin rate is also shown on the Home page (see Section 4.1 Home).
Return Mode	Single Return: <ul style="list-style-type: none"> • First • Strongest • Last • Second Dual Return: <ul style="list-style-type: none"> • First and Last (default) • Last and Strongest • First and Strongest • Strongest and Second Strongest • First and Second 	Also shown in Point Cloud Data Packets (see the Return Mode field in Section 3.1.2.5 Tail).

Parameter	Options	Description
Sync Angle	0° to 360°	<p>Phase lock angle</p> <ul style="list-style-type: none"> To activate this function, check the checkbox and input an azimuth. At every full second, the lidar will rotate to that azimuthal position. <div style="border: 1px dashed gray; padding: 5px; margin-top: 10px;"> <p> Lidar azimuthal position is defined in Section 1.3 Basic structure.</p> </div> <div style="border: 1px dashed gray; padding: 5px; margin-top: 10px;"> <p>Definition of the full second (detailed in Section B.1 Source of absolute time):</p> <ul style="list-style-type: none">  When PTP is tracking or locked, the full second is retrieved from the PTP signal. (PPS signal is not required nor used.) When PTP is frozen or in free run, the full second is defined as the rising edge of the lidar's internal 1 Hz signal. </div> <p>To phase-lock multiple lidar units, connect them to the same clock source and set the same sync angle. These lidar units will rotate to the same azimuthal position at every full second.</p>
Trigger Method	Angle-Based Time-Based (default)	<p>The way laser firings are triggered.</p> <p>Angle-Based Lasers fire every 0.4° at 10 Hz, or every 0.8° at 20 Hz.</p> <p>Time-Based Lasers fire every 111.11 μs.</p>
Up-Close Blockage Detection	OFF (default) ON	<p>When no point cloud is output, the following two circumstances can be distinguished:</p> <ul style="list-style-type: none"> No laser emission. With laser emission, no point cloud data is valid. <p>See the definition of the Distance field in Section 3.1.2 Point cloud UDP data.</p>
Retro Multi-Reflection Filtering	OFF (default) ON	To reduce the false positives at twice the distance of a retroreflector.

Parameter	Options	Description
Rotation Direction	Clockwise (default) Counterclockwise	 After selecting Counterclockwise, refresh the webpage to check that the settings have taken effect. If the page after refreshing still shows Clockwise, refresh the page again and check.
Standby Mode	In Operation (default) Standby	In Standby mode, the motor stops running and lasers stop firing.

4.2.3 Time sync

Clock Source	PTP
Profile	1588v2
PTP Network Transport	UDP/IP
PTP Domain Number	0
PTP logAnnounceInterval	1
PTP logSyncInterval	1
PTP logMinDelayReqInterval	0
Time Offset for Lidar Lock	1

Parameter	Options	Description				
Clock Source	Fixed: PTP	External source of absolute time				
Profile	1588v2 (default) 802.1AS 802.1AS Automotive	IEEE timing and synchronization standard				
Time Offset for Lidar Lock	1 to 100 μ s (integer) Default: 1	Specify the upper limit of the absolute offset between Slave and Master when the lidar is in PTP Locked status; see Section 4.1 Home .				
PTP Network Transport	UDP/IP (default) L2	Network transport protocol <table border="1" data-bbox="1131 1145 2072 1264"> <tr> <td>UDP/IP</td> <td>Available only for 1588v2 profile</td> </tr> <tr> <td>L2</td> <td>Available for all profiles</td> </tr> </table>	UDP/IP	Available only for 1588v2 profile	L2	Available for all profiles
UDP/IP	Available only for 1588v2 profile					
L2	Available for all profiles					
Domain Number	0 to 127 (integer) Default: 0	Domain attribute of the local clock				

When using the 1588v2 profile, these additional parameters can be configured:

Parameter	Options	Description
PTP logAnnounceInterval	-2 to 3	Time interval between Announce messages Default: 1 (2 seconds)
PTP logSyncInterval	-7 to 3	Time interval between Sync messages Default: 1 (2 seconds)
PTP logMinDelayReqInterval	-7 to 3	Minimum permitted mean time between Delay_Req messages Default: 0 (1 second)

When using the 802.1AS or 802.1AS Automotive profile:

Parameter	Options	Description				
Switch Type	TSN (default) Non-TSN	Type of the network switch <table border="1" data-bbox="913 788 2069 908"> <tbody> <tr> <td>TSN</td> <td>Time Sensitive Network, using Peer-to-Peer delay mechanism</td> </tr> <tr> <td>Non-TSN</td> <td>Using End-to-End delay mechanism</td> </tr> </tbody> </table>	TSN	Time Sensitive Network, using Peer-to-Peer delay mechanism	Non-TSN	Using End-to-End delay mechanism
TSN	Time Sensitive Network, using Peer-to-Peer delay mechanism					
Non-TSN	Using End-to-End delay mechanism					

4.3 Azimuth FOV

Azimuth FOV Setting	For all channels ▼
Save	

Buttons

Save Save and execute all the settings on this page.

Parameter	Options	Description
Azimuth FOV Setting	For all channels (default) Multi-section FOV	Configuration mode of the azimuth FOV The lidar outputs valid data only within the specified azimuth FOV ranges.



- The angles in degrees are accurate to the first decimal place.
- If the Start Angle is larger than the End Angle, then the actual range is the union of [Start Angle, 360°) and [0°, End Angle).
For instance, when the angle range is set to be [270°, 90°), the actual azimuth FOV is [270°, 360°) ∪ [0°, 90°).

4.3.1 For All Channels

Input a start angle and an end angle to form a continuous angle range [Start, End].

This range applies to all channels.

Azimuth FOV Setting		For all channels
Azimuth FOV for All Channels	Start:	0.0
	End:	360.0
Save		

4.3.2 Multi-section FOV

For each of the eight channel groups (16 channels per group, starting from Channel 1), input multiple (≤ 2) sets of Start Angles and End Angles to form multiple continuous angle ranges.

Azimuth FOV Setting		Multi-section FOV		
Group Channel	Azimuth FOV 1		Azimuth FOV 2	
	Start angle	End angle	Start angle	End angle
1 to 16	0.0	0.0	0.0	0.0
17 to 32	0.0	0.0	0.0	0.0
33 to 48	0.0	0.0	0.0	0.0
49 to 64	0.0	0.0	0.0	0.0
65 to 80	0.0	0.0	0.0	0.0
81 to 96	0.0	0.0	0.0	0.0
97 to 112	0.0	0.0	0.0	0.0
113 to 128	0.0	0.0	0.0	0.0

Save

4.4 Operation Statistics

These operating parameters are shown in real time:

Start-Up Counts	510
Internal Temperature	32.10°C
System Uptime	0 h 5 min
Total Operation Time	559 h 43 min
Internal Temperature	Operation Time
< -40°C	0 h 1 min
-40 to -20°C	0 h 46 min
-20 to 0°C	0 h 49 min
0 to 20°C	8 h 40 min
20 to 40°C	38 h 20 min
40 to 60°C	393 h 17 min
60 to 80°C	109 h 50 min
80 to 100°C	6 h 16 min
100 to 120°C	1 h 44 min
> 120°C	0 h 0 min

4.5 Monitor

These electrical parameters (measured at the lidar's external connector) are shown in real time.

- Lidar Input Current
- Lidar Input Voltage
- Lidar Input Power

4.6 Upgrade



- Before upgrading, please contact Hesai technical support to obtain the .patch file.
- It is recommended to place a protective cover or other opaque material over the lidar's cover lens when upgrading.
- The instructions for downgrading are the same as those for upgrading.

Upgrade steps

1. Click the [**Upload**] button and select a .patch file to start the upgrade.
2. Wait for the process to be 100% complete. The lidar will automatically reboot.
3. The latest version numbers will display in "Upgrade" and "Home" pages.



If the upgrade fails, hard restart the lidar and try again.

Buttons

Upload	To upload the .patch file This product model supports cybersecurity and only accepts encrypted and signed upgrade files.
Restart	Software reboot Afterward, the Start-Up Counts in the Operation Statistics page increments by 1; see Section 4.4 Operation Statistics .

Parameter	Current version
Software version	3.1.66
Firmware of sensor version	3.1.36
Firmware of controller version	3.1.40
Upgrade log	-



The above version numbers may be different. The actual web page shall prevail.

4.7 Log

The process logs on this page can be used for software troubleshooting.

Button description

Clear ALL	Clear all logs
Download ALL	Download all logs

4.8 Security

Cyber security (Master Switch): OFF

Cyber Security (Master Switch)	OFF
Login Control	
Authentication	OFF
Secure Connection	
PTC Connection	Non-TLS
HTTP Connection	HTTP
Point Cloud Signature	
Share Secret Key ⓘ	
Save	

Cyber security (master switch): ON

Cyber Security (Master Switch)	ON
Login Control	
Authentication	ON
Current Password	_____ Forgot Password?
New Password	_____
Confirm New Password	_____
Secure Connection	
PTC Connection	TLS
HTTP Connection	HTTPS
Point Cloud Signature	
Share Secret Key ⓘ	
Save	

As shown in the previous page, the available settings depend on the Cyber Security Master Switch:

	Cyber Security (Master Switch): OFF (default)	Cyber Security (Master Switch): ON
Login Control	OFF http:// 192.168.1.201 redirects to the Home page.	ON https:// 192.168.1.201 redirects to the Login page.
Secure Connection	OFF PTC and HTTP (cleartext communication)	ON PTCS and HTTPS (encrypted communication; configuration required)
Point Cloud Signature	Setting the Shared Secret Key in cleartext poses data breach risks and is not recommended.	Users can change the shared secret key.



- Point cloud signature is deactivated by default. Its activation/deactivation is controlled by PTC commands (see [Section 2.5 Tools](#)), regardless of the Cyber Security Master Switch. This webpage only sets the Shared Secret Key of point cloud signature.
- Firmware and software upgrades are always encrypted and signed, regardless of the Cyber Security Master Switch.

4.8.1 Login control

When the Cyber Security Master Switch is ON:

Parameter	Options	Description
Authentication	Fixed: ON	Login control
Current password	-	When turning on/off the Cyber Security Master Switch or when changing the password, input here. <ul style="list-style-type: none"> • Default password: 123456 • To effectively implement login control, please change the default password and keep your new password securely. • Before returning a trial/loaner lidar or an RMA lidar to Hesai, please make sure to change the password back to default.
New password	-	Format <ul style="list-style-type: none"> • 8 to 30 characters • Containing at least one digit and one letter (case sensitive) • Special characters are allowed
Confirm new password	-	-

If you forget the password:

If TLS is selected for PTC Connection	Users should reset the password : <ol style="list-style-type: none"> 1. Click "Forgot password?" and it will redirect to the Reset Password page. 2. Obtain a reset code. 3. Contact technical support and provide the reset code to obtain a verification code. 4. Input the verification code in the Reset Password page and click the [Submit] button.
If mTLS is selected for PTC Connection	Users are allowed to change the password (without providing the current password) by sending a PTCS command (see Section 2.5 Tools).

4.8.2 Secure Connection

When the Cyber Security Master Switch is ON:

TLS

Secure Connection	
PTC Connection	TLS
HTTP Connection	HTTPS

mTLS

Secure Connection	
PTC Connection	mTLS
Client CA Certificate	No file
Certificate Status	Invalid
Change Certificate	<input type="button" value="Upload"/> <input type="button" value="Remove"/>
HTTP Connection	HTTPS

Parameter	Options	Description		
PTC connection	TLS (default) mTLS	PTC connection mode		
		<table border="1"> <tr> <td>TLS (one-way auth)</td> <td>Only the user authenticates the lidar.</td> </tr> <tr> <td>mTLS (two-way authentication)</td> <td> The user and the lidar authenticate each other. Recommended for enhanced security. <ul style="list-style-type: none"> Click the [Upload] button to upload a user CA certificate chain. Before returning a trial/loaner lidar or an RMA lidar to Hesai, click the [Remove] button to remove the uploaded certificate. </td> </tr> </table>	TLS (one-way auth)	Only the user authenticates the lidar.
TLS (one-way auth)	Only the user authenticates the lidar.			
mTLS (two-way authentication)	The user and the lidar authenticate each other. Recommended for enhanced security. <ul style="list-style-type: none"> Click the [Upload] button to upload a user CA certificate chain. Before returning a trial/loaner lidar or an RMA lidar to Hesai, click the [Remove] button to remove the uploaded certificate. 			

Parameter	Options	Description
HTTP Connection	Fixed: HTTPS	<p>HTTP connection mode</p> <p>After configuring the HTTPS environment (see Section 4.8.4 Configure HTTPS environment):</p> <ul style="list-style-type: none">• The current URL switches from http://192.168.1.201 to https://192.168.1.201.• Communication becomes encrypted.

4.8.3 Point cloud signature

Parameter	Options	Description
Shared secret key	-	<p>Used for negotiating a session key</p> <ul style="list-style-type: none">• Default key: 12345678• To avoid data breach risks, please change the default key and keep your new key securely. <p>Format: 8 to 32 digits or letters (case sensitive)</p>

4.8.4 Configure HTTPS environment

Before using HTTPS, import the lidar CA certificate chain into your browser.



Without this step, HTTPS will not be activated, and a browser warning ("Not Secure") will appear when accessing Web Control.

Follow these steps to set up certificates in Chrome or Firefox (Windows 10).

1. Go to the "Settings".
2. Input "Certificates" in the search bar.
 - **Chrome:** Select [**Security**] > [**Manage device certificates**].
 - **Firefox:** Select [**View Certificates**].

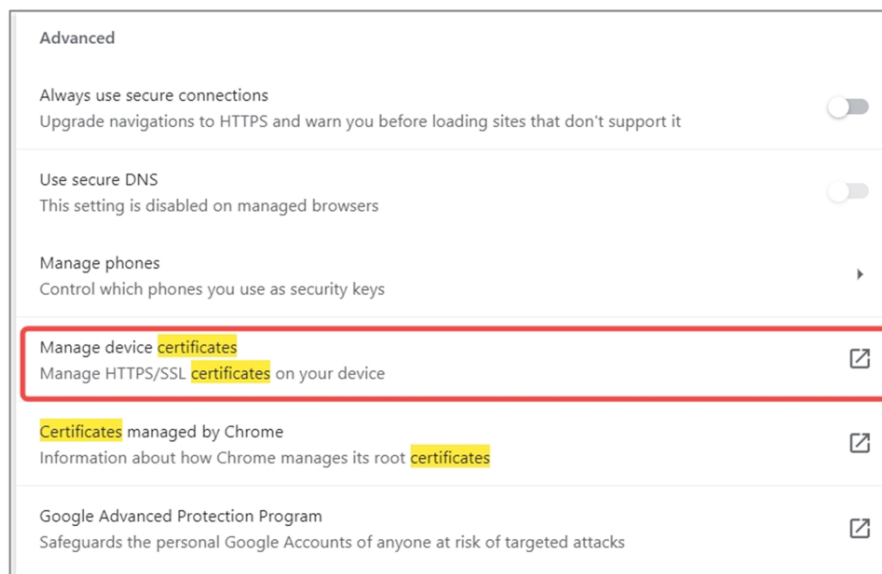

Figure 17. In Chrome

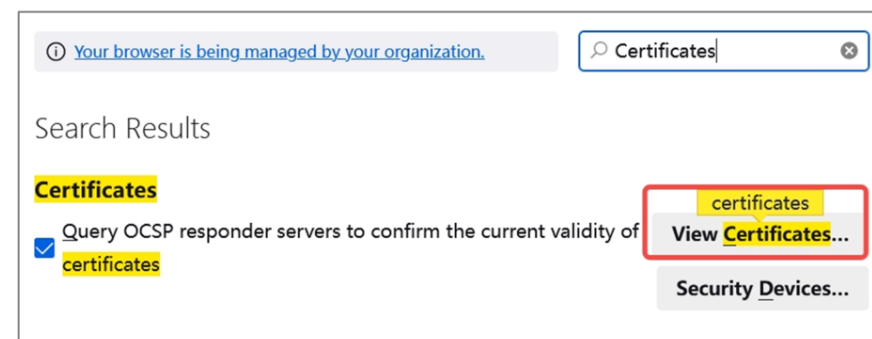

Figure 18. In Firefox

3. Upload intermediate and root certificates

- **Chrome:**

- a. Click [**Intermediate Certificate Authorities**] tab > Click [**Import**] to upload the intermediate certificate.

- b. Click [**Trusted Root Certification Authorities**] tab > Click [**Import**] to upload the root certificate.

- **Firefox:**

- Click [**Authorities**] tab > Click [**Import**] to upload the intermediate and root certificates, or upload the certificate chain file only.

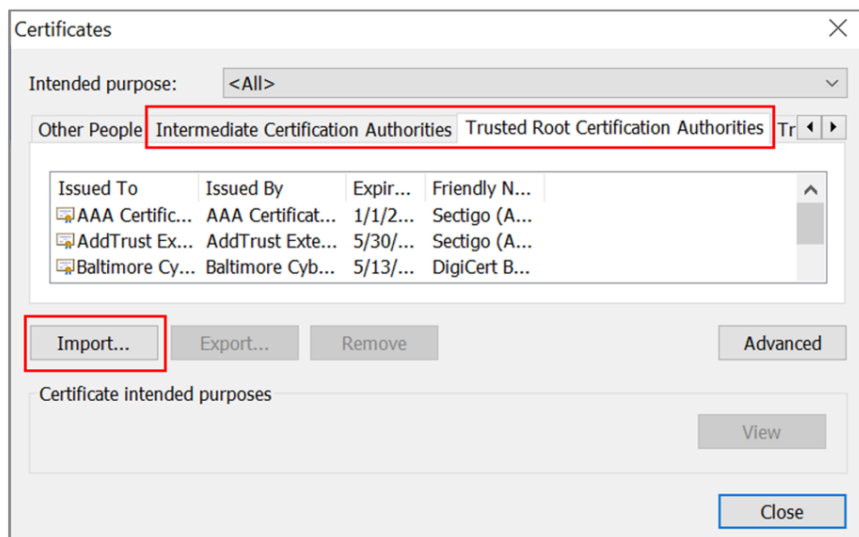

Figure 19. In Chrome

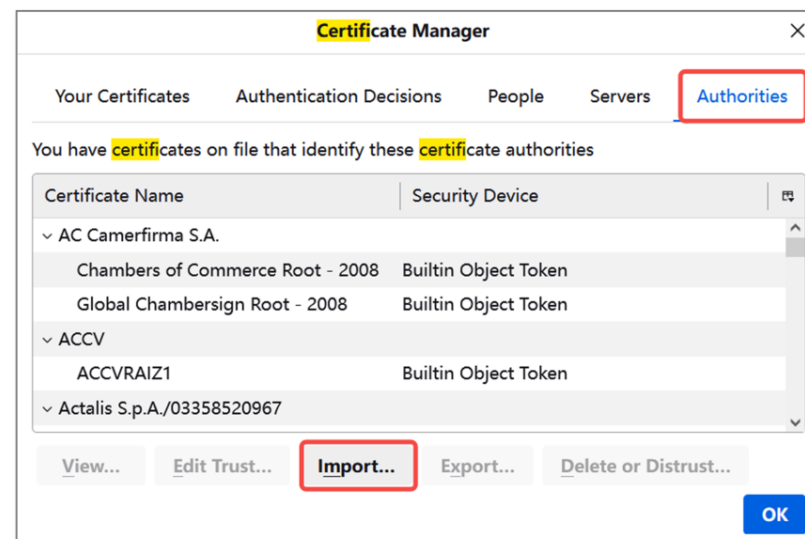

Figure 20. In Firefox

4. If a "Security Warning" or "Downloading Certificate" dialog box appears:
- **Chrome:** Click [**Yes**].
 - **Firefox:** Select [**Trust this CA to identify websites**] > Click [**OK**].

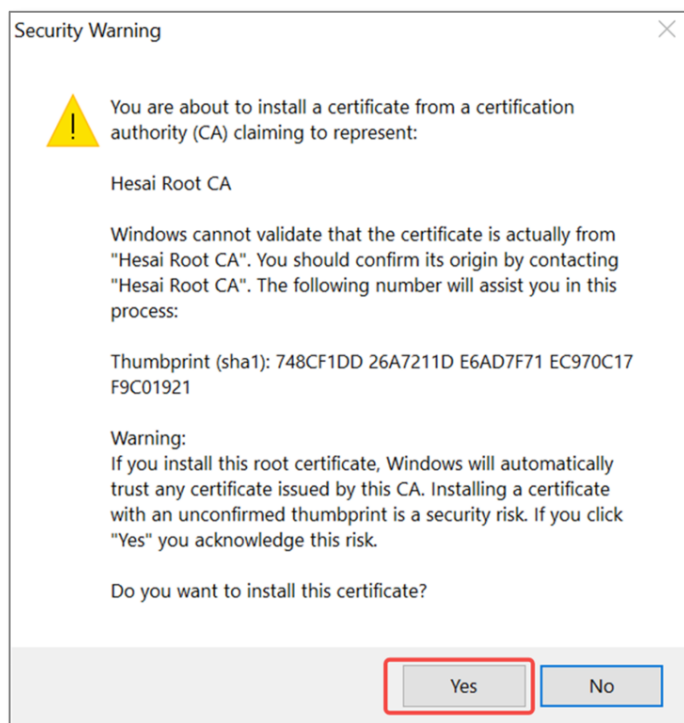

Figure 21. In Chrome

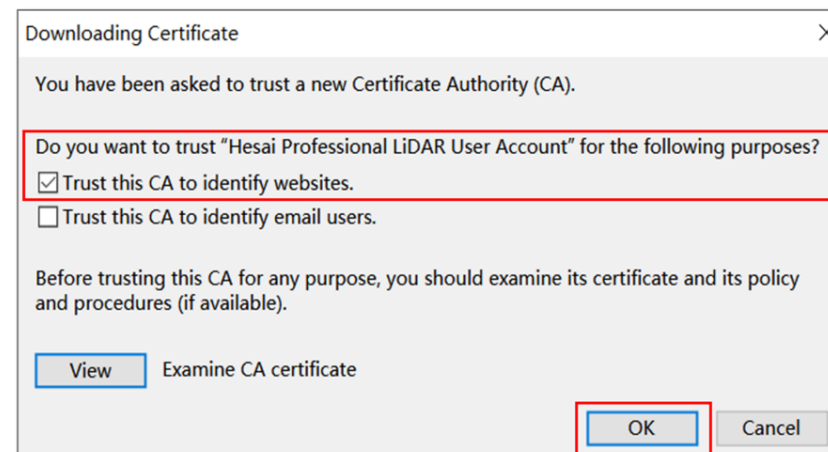

Figure 22. In Firefox

5. The newly-added CAs will appear in the list. Double-click to view more detailed information.

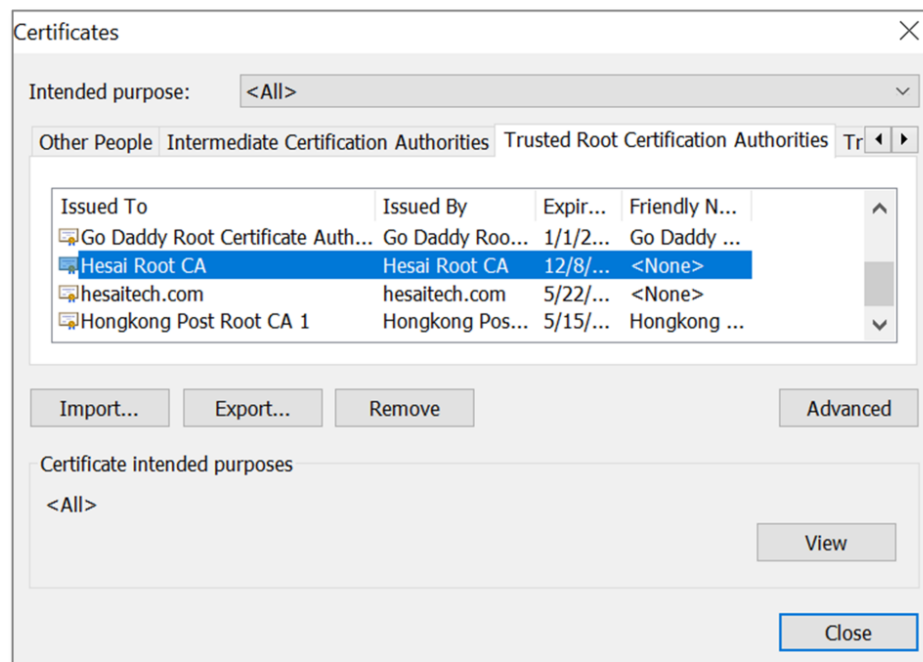

Figure 23. In Chrome

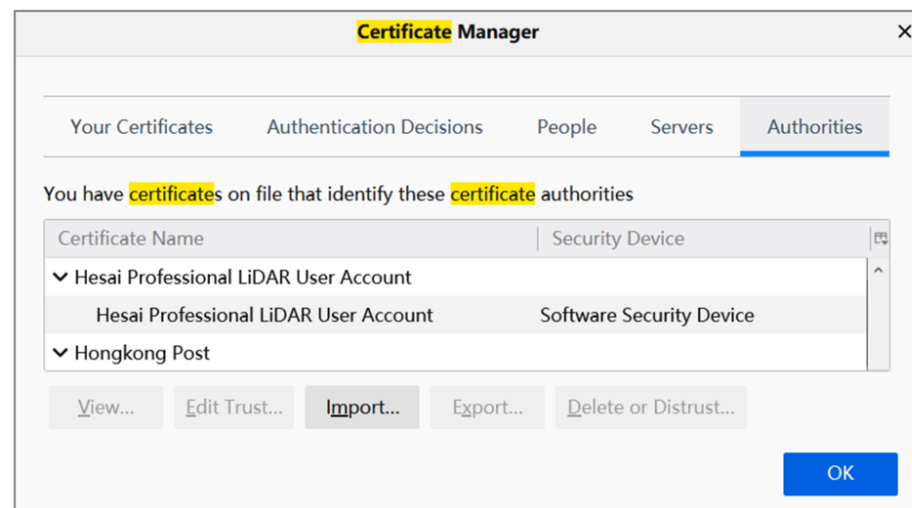
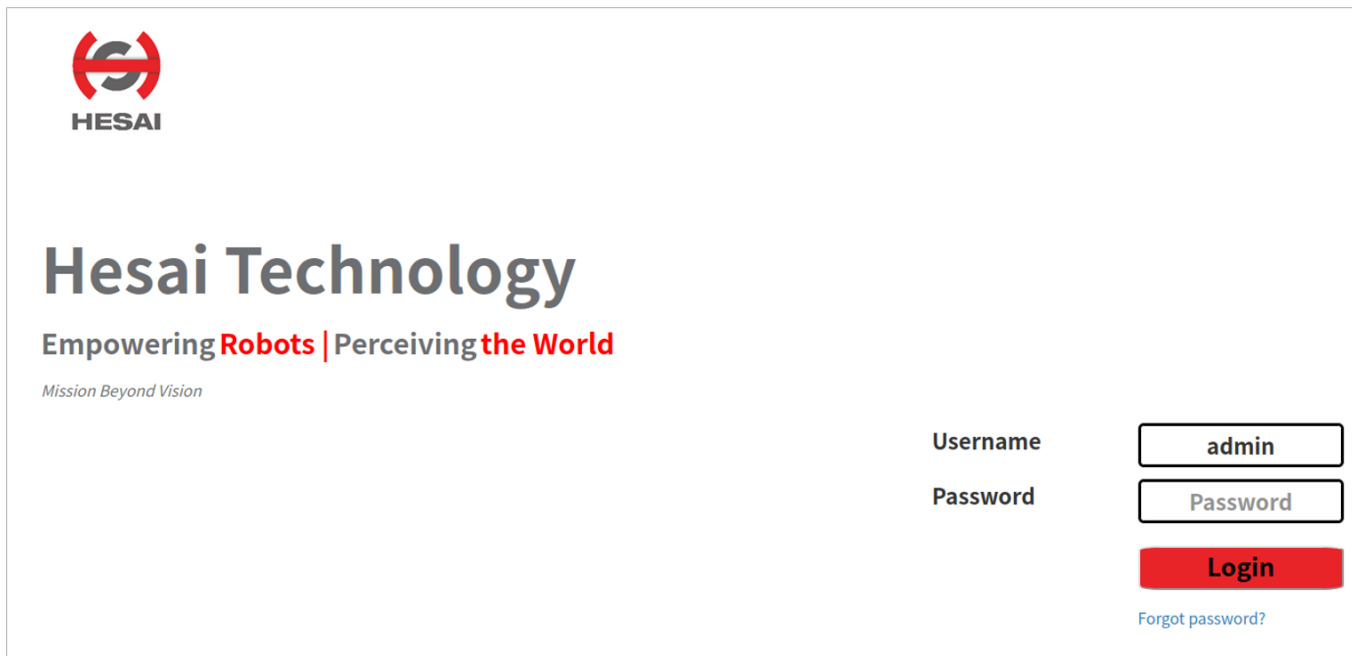

Figure 24. In Firefox

4.9 Login

When the Cyber Security Master Switch on the [Security](#) page is ON, login control will be activated and the current URL will redirect to the Login page.



Parameter	Options	Description
Username	admin	-
Password	-	Default: 123456 To effectively implement login control, please change the default password (see Section 4.8.1 Login control) and keep your new password securely.

5 Maintenance

The lidar's cover lens is made of plastic (polycarbonate, PC), similar to the material used for car lamps.

- Do NOT wipe the cover lens when it is dry, nor use abrasive cleaners. Doing so can damage the optical coating.
- Do NOT use organic cleaners, which can damage the cover lens and even cause cracking.
 - Organic cleaners include but are not limited to tar removers, self-cleaning agents, adhesive removers, coating removers, foam cleaners, iron powder removers for car paint, glass cleaners, thinning agents, de-icers, paint surface treatment agents, alcohol, and vinegar.
 - If organic cleaners may be present when cleaning the equipment or performing related operations, please protect the cover lens to prevent any contact with organic cleaners.
- Do NOT apply excessive force to the lidar, as this can damage the cover lens.
 - If a pressure washer is used to clean the cover lens, make sure the distance between the nozzle and the cover lens remains at least 60 cm.
 - Using automatic cleaning devices that are not specifically designed for lidars may pose risks. Please contact Hesai technical support for assessment.
 - Do NOT use sharp objects (such as knives or metal tweezers) or hard brushes (such as stiff nylon brushes or wire brushes) to scratch the cover lens cover surface. Such actions may damage the cover lens surface, and in severe cases, may cause malfunction.
- After prolonged exposure to strong sunlight and high temperatures, the cover lens should NOT be cleaned immediately.
- If snow or ice accumulates on the cover lens, do NOT use a pressure washer or ice scraper.
 - A small broom is recommended to remove snow.
 - A solvent-free (i.e., free of organic solvents) ice removal spray is recommended to remove ice; alternatively, wait for the ice to melt by itself.
- Do NOT wax the cover lens.



Please regularly check on the cover lens, considering your use frequency, storage environment, and climate conditions.



- If foreign objects (such as dust, fingerprints, or oil stains) are found on the cover lens, make sure to clean them.
- If corrosive foreign objects (such as insect remains, bird droppings, tree resin, road dust, industrial dust, asphalt, soot particles, and road salt) are found on the cover lens, make sure to clean them immediately.

Cleaning procedure

1. Make sure the lidar is powered OFF.
2. Choose an appropriate cleaning agent:
 - For light stains, use room temperature water.
 - For heavier stains, use a mild soap solution (no more than two tablespoons of soap per quart or liter of water).
 - For stubborn stains, use a solvent-free (i.e., free of organic solvents), pH-neutral detergent at room temperature, such as car shampoo.
3. Take a clean soft sponge or anti-static microfiber cloth, dampen it with the chosen cleaning agent, and gently wipe the dirty area on the cover lens back and forth.
4. For stubborn stains, cover the dirty area with the dampened sponge or cloth to soften the stains before wiping.
5. Immediately after removing the stains, rinse the cover lens with clean water. Then, use a clean soft sponge or microfiber cloth to gently wipe away any remaining liquid (which may contain residual cleaning agents or contaminants).

6 Troubleshooting

If the following procedures cannot solve your problem, please contact Hesai technical support.

Symptoms	Points to check
Indicator light is off on the connection box.	<p>Make sure that the following conditions are met:</p> <ul style="list-style-type: none"> • The power adapter is properly connected and in good condition. • The connection box is intact. • The input voltage and input current satisfy the requirements in Section 2.3 Connection box (optional). <p>Afterward, power on the lidar again and check if the symptom persists.</p>
Motor is not running.	<p>Make sure that the following conditions are met:</p> <ul style="list-style-type: none"> • The power adapter is properly connected and in good condition. • The input voltage and input current satisfy the requirements in Section 1.5 Specifications. • The lidar can be accessed using Web Control (see Cannot open Web Control). • The lidar is not in standby mode; this can be confirmed using Web Control or PTC commands. • If a connection box is used, the connection box is intact. <p>Afterward, power on the lidar again and check if the symptom persists.</p>
Motor is running, but no output data is received, neither by Wireshark nor by PandarView 2.	<p>Make sure that the following conditions are met:</p> <ul style="list-style-type: none"> • The Ethernet cable is properly connected (by unplugging and plugging again). • Destination IP is correctly set; this can be confirmed using Web Control or PTC commands. • Firmware version is correct; this can be confirmed using Web Control or PTC commands. • Azimuth FOV is correctly set; this can be confirmed using Web Control or PTC commands. • The lidar is emitting laser light; this can be confirmed using an infrared camera, an infrared sensor card, or a phone camera without an IR-cut filter. • If a connection box is used, replace the current Ethernet cable with another cable of at least Cat 6; Cat 7 or higher is recommended. <p>Afterward, power on the lidar again and check if the symptom persists.</p>

Symptoms	Points to check
Output data can be received by Wireshark but not by PandarView 2.	<p>Make sure that the following conditions are met:</p> <ul style="list-style-type: none">• Lidar Destination Port is correctly set; this can be confirmed using Web Control or PTC commands.• The computer's firewall for public networks is turned off, or PandarView 2 is added to firewall exceptions.• The latest PandarView 2 is installed (see Downloads page of Hesai's official website or contact Hesai technical support). <p>Afterward, power on the lidar again and check if the symptom persists.</p>
Cannot open Web Control.	<p>Make sure that the following conditions are met:</p> <ul style="list-style-type: none">• Ethernet cable is properly connected (by unplugging and plugging again).• The lidar's IP is in the same subnet with the computer's (WireShark may be used to check the lidar's IP that broadcasts data packets). <p>Afterward, follow these steps:</p> <ol style="list-style-type: none">1. Restart the computer or connect the lidar to another computer.2. Power on the lidar again and check if the symptom persists.

Symptoms	Points to check
<p>Point cloud is abnormal, showing obviously misaligned points, flashing points, or incomplete FOV.</p>	<p>Make sure that the following conditions are met:</p> <ul style="list-style-type: none"> • The lidar's cover lens is clean. If not, refer to Section 5 Maintenance for the cleaning method. • The lidar's angle correction file is applied (refer to PandarView 2 User Manual). • Azimuth FOV is properly set; this can be confirmed using Web Control or PTC commands. • Spin Rate is steady; this can be confirmed either by checking the Motor Speed field (if available) in Point Cloud Data Packets, or by using Web Control, PandarView 2 or PTC commands. • The lidar's internal temperature is between -40°C and 110°C; this can be confirmed using Web Control, PandarView 2 or PTC commands. <p>Afterward, check for packet loss.</p> <p>If no packet is lost yet the point cloud flashes, try these steps:</p> <ol style="list-style-type: none"> 1. Update PandarView 2 to the latest version (see Downloads page of Hesai's official website or contact Hesai technical support). 2. Restart the computer. <p>If the point cloud is still abnormal, try these steps:</p> <ol style="list-style-type: none"> 1. Connect the lidar to another computer and another network. 2. Power on again and check if the symptom persists.

Symptoms	Points to check
The number of data packets received is abnormal, indicating missing packets.	<p>Make sure that the following conditions are met:</p> <ul style="list-style-type: none">• Azimuth FOV is properly set; this can be confirmed using Web Control or PTC commands.• Spin Rate is steady; this can be confirmed either by checking the Motor Speed field (if available) in Point Cloud Data Packets, or by using Web Control, PandarView 2 or PTC commands.• The lidar's internal temperature is between -40°C and 110°C; this can be confirmed using Web Control, PandarView 2 or PTC commands.• Ethernet is not overloaded.• No switch is connected to the network (the data transmitted from other devices may cause network congestion and packet loss). <p>Afterward, follow these steps:</p> <ol style="list-style-type: none">1. Connect the computer to no other devices but the lidar and check for packet loss.2. Power on the lidar again and check if the symptom persists.

Appendix A: Channel distribution data

Notes to the table

Angles

- The design values of Horizontal Angle (Azimuth) Offsets and Vertical Angles (Elevation) are listed.
- The accurate values are in this lidar unit's angle correction file; see [Section 1.4 Channel distribution](#).

Channel number

All channels are listed in the ascending order of Channel No.

In the vertical high-resolution region (19° to 36°), the vertical angles of Channels 78 to 96 alternate with those of Channels 97 to 115. Outside this region, Channel No. counts from bottom to top.

Division of Channels into Banks

All channels are divided into four banks.

Range of Channels	Name
Channels 97 to 128	Bank D
Channels 65 to 96	Bank C
Channels 33 to 64	Bank B
Channels 1 to 32	Bank A

Channel No.	Bank No.	Horizontal angle (azimuth) offset	Vertical angle (elevation)	Ranging capability @10% Reflectivity	Horizontal resolution @10 Hz
1	A	10.108°	-52.627°	15 m	0.8°
2	A	9.720°	-51.028°	15 m	0.8°
3	A	9.384°	-49.515°	15 m	0.8°
4	A	9.091°	-48.074°	15 m	0.8°
5	A	8.833°	-46.695°	15 m	0.8°
6	A	8.603°	-45.369°	15 m	0.8°

Channel No.	Bank No.	Horizontal angle (azimuth) offset	Vertical angle (elevation)	Ranging capability @10% Reflectivity	Horizontal resolution @10 Hz
7	A	8.396°	-44.090°	15 m	0.8°
8	A	8.209°	-42.852°	15 m	0.8°
9	A	8.040°	-41.651°	20 m	0.8°
10	A	7.885°	-40.482°	20 m	0.8°
11	A	7.743°	-39.343°	20 m	0.8°
12	A	7.612°	-38.231°	20 m	0.8°
13	A	7.492°	-37.143°	20 m	0.8°
14	A	7.380°	-36.076°	20 m	0.8°
15	A	7.277°	-35.030°	20 m	0.8°
16	A	7.180°	-34.002°	20 m	0.8°
17	A	7.090°	-32.992°	20 m	0.8°
18	A	7.006°	-31.996°	20 m	0.8°
19	A	6.928°	-31.015°	20 m	0.8°
20	A	6.854°	-30.048°	20 m	0.8°
21	A	6.785°	-29.093°	20 m	0.8°
22	A	6.721°	-28.149°	20 m	0.8°
23	A	6.660°	-27.216°	20 m	0.8°
24	A	6.602°	-26.292°	20 m	0.8°
25	A	6.549°	-25.378°	20 m	0.8°
26	A	6.498°	-24.473°	20 m	0.8°

Channel No.	Bank No.	Horizontal angle (azimuth) offset	Vertical angle (elevation)	Ranging capability @10% Reflectivity	Horizontal resolution @10 Hz
27	A	6.450°	-23.575°	20 m	0.8°
28	A	6.405°	-22.685°	20 m	0.8°
29	A	6.363°	-21.802°	20 m	0.8°
30	A	6.323°	-20.926°	20 m	0.8°
31	A	6.285°	-20.056°	20 m	0.8°
32	A	6.250°	-19.191°	20 m	0.8°
33	B	-6.217°	-18.331°	20 m	0.8°
34	B	-6.186°	-17.477°	20 m	0.8°
35	B	-6.157°	-16.627°	20 m	0.8°
36	B	-6.129°	-15.781°	20 m	0.8°
37	B	-6.104°	-14.940°	20 m	0.8°
38	B	-6.080°	-14.102°	20 m	0.8°
39	B	-6.057°	-13.268°	20 m	0.8°
40	B	-6.037°	-12.436°	20 m	0.8°
41	B	-6.018°	-11.608°	20 m	0.8°
42	B	-6.000°	-10.783°	20 m	0.8°
43	B	-5.984°	-9.960°	20 m	0.8°
44	B	-5.969°	-9.139°	20 m	0.8°
45	B	-5.955°	-8.320°	20 m	0.8°
46	B	-5.943°	-7.503°	20 m	0.8°

Channel No.	Bank No.	Horizontal angle (azimuth) offset	Vertical angle (elevation)	Ranging capability @10% Reflectivity	Horizontal resolution @10 Hz
47	B	-5.927°	-6.688°	20 m	0.8°
48	B	-5.923°	-5.874°	20 m	0.8°
49	B	-5.915°	-5.061°	20 m	0.8°
50	B	-5.908°	-4.250°	20 m	0.8°
51	B	-5.902°	-3.439°	20 m	0.8°
52	B	-5.897°	-2.630°	20 m	0.8°
53	B	-5.894°	-1.820°	20 m	0.8°
54	B	-5.892°	-1.012°	20 m	0.8°
55	B	-5.891°	-0.203°	20 m	0.8°
56	B	-5.891°	0.606°	20 m	0.8°
57	B	-5.893°	1.414°	20 m	0.8°
58	B	-5.896°	2.223°	20 m	0.8°
59	B	-5.899°	3.033°	20 m	0.8°
60	B	-5.905°	3.843°	20 m	0.8°
61	B	-5.911°	4.654°	20 m	0.8°
62	B	-5.919°	5.466°	20 m	0.8°
63	B	-5.927°	6.279°	20 m	0.8°
64	B	-5.938°	7.094°	20 m	0.8°
65	C	5.949°	7.910°	20 m	0.4°
66	C	5.962°	8.728°	20 m	0.4°

Channel No.	Bank No.	Horizontal angle (azimuth) offset	Vertical angle (elevation)	Ranging capability @10% Reflectivity	Horizontal resolution @10 Hz
67	C	5.976°	9.547°	20 m	0.4°
68	C	5.992°	10.369°	20 m	0.4°
69	C	6.008°	11.194°	20 m	0.4°
70	C	6.027°	12.020°	20 m	0.4°
71	C	6.047°	12.850°	20 m	0.4°
72	C	6.068°	13.683°	20 m	0.4°
73	C	6.091°	14.519°	20 m	0.4°
74	C	6.116°	15.359°	20 m	0.4°
75	C	6.143°	16.202°	20 m	0.4°
76	C	6.171°	17.050°	20 m	0.4°
77	C	6.201°	17.902°	20 m	0.4°
78	C	6.233°	18.759°	20 m	0.4°
79	C	6.267°	19.621°	20 m	0.4°
80	C	6.304°	20.488°	20 m	0.4°
81	C	6.343°	21.362°	20 m	0.4°
82	C	6.384°	22.241°	20 m	0.4°
83	C	6.427°	23.128°	20 m	0.4°
84	C	6.474°	24.022°	20 m	0.4°
85	C	6.523°	24.923°	20 m	0.4°
86	C	6.575°	25.833°	20 m	0.4°

Channel No.	Bank No.	Horizontal angle (azimuth) offset	Vertical angle (elevation)	Ranging capability @10% Reflectivity	Horizontal resolution @10 Hz
87	C	6.631°	26.751°	20 m	0.4°
88	C	6.690°	27.679°	20 m	0.4°
89	C	6.752°	28.618°	20 m	0.4°
90	C	6.819°	29.567°	20 m	0.4°
91	C	6.890°	30.528°	20 m	0.4°
92	C	6.966°	31.502°	20 m	0.4°
93	C	7.047°	32.490°	20 m	0.4°
94	C	7.134°	33.493°	20 m	0.4°
95	C	7.227°	34.512°	20 m	0.4°
96	C	7.327°	35.549°	20 m	0.4°
97	D	-6.250°	19.191°	20 m	0.4°
98	D	-6.285°	20.056°	20 m	0.4°
99	D	-6.323°	20.926°	20 m	0.4°
100	D	-6.363°	21.802°	20 m	0.4°
101	D	-6.405°	22.685°	20 m	0.4°
102	D	-6.450°	23.575°	20 m	0.4°
103	D	-6.498°	24.473°	20 m	0.4°
104	D	-6.549°	25.378°	20 m	0.4°
105	D	-6.602°	26.292°	20 m	0.4°
106	D	-6.660°	27.216°	20 m	0.4°

Channel No.	Bank No.	Horizontal angle (azimuth) offset	Vertical angle (elevation)	Ranging capability @10% Reflectivity	Horizontal resolution @10 Hz
107	D	-6.721°	28.149°	20 m	0.4°
108	D	-6.785°	29.093°	20 m	0.4°
109	D	-6.854°	30.048°	20 m	0.4°
110	D	-6.928°	31.015°	20 m	0.4°
111	D	-7.006°	31.996°	20 m	0.4°
112	D	-7.090°	32.992°	20 m	0.4°
113	D	-7.180°	34.002°	20 m	0.4°
114	D	-7.277°	35.030°	20 m	0.4°
115	D	-7.380°	36.076°	20 m	0.4°
116	D	-7.492°	37.143°	20 m	0.4°
117	D	-7.612°	38.231°	20 m	0.4°
118	D	-7.743°	39.343°	20 m	0.4°
119	D	-7.885°	40.482°	20 m	0.4°
120	D	-8.040°	41.651°	20 m	0.4°
121	D	-8.209°	42.852°	15 m	0.4°
122	D	-8.396°	44.090°	15 m	0.4°
123	D	-8.603°	45.369°	15 m	0.4°
124	D	-8.833°	46.695°	15 m	0.4°
125	D	-9.091°	48.074°	15 m	0.4°
126	D	-9.384°	49.515°	15 m	0.4°

Channel No.	Bank No.	Horizontal angle (azimuth) offset	Vertical angle (elevation)	Ranging capability @10% Reflectivity	Horizontal resolution @10 Hz
127	D	-9.720°	51.028°	15 m	0.4°
128	D	-10.108°	52.627°	15 m	0.4°

Description of Row 1

Field	Description
Beginning of File	Fixed: 0xEE FF
Protocol Version Major	Current value: 0x01
Protocol Version Minor	Current value: 0x01

Appendix B: Absolute time of point cloud data

B.1 Source of absolute time

The lidar retrieves the current absolute time by connecting to an external clock source.

B.1.1 PTP as the clock source

The lidar connects to a third-party PTP master to obtain PTP signal.



- PPS signal is not required nor used.
- PTP can be configured using Web Control or PTC commands.
- The status of PTP signal can be found using Web Control or PTC commands.

The absolute time is updated as follows:

PTP status	Date and time (accurate to the microsecond)	Lidar behavior
Free run	Virtual	Because the lidar has not been locked before, it starts counting from a virtual UTC (such as 2000-01-01 00:00:00) using the lidar's internal 1 Hz signal.
Tracking or Locked	Synchronized	The lidar extracts the actual date and time from the PTP master's messages.
Frozen	Drifting	When the lidar goes from Tracking/Locked to Frozen, it starts counting from the last synchronized time using the lidar's internal 1 Hz signal. This absolute time will gradually drift from the actual PTP time.



- PTP is a Plug & Play protocol; the lidar works as a PTP slave device and requires no additional setup.
- The **UTC Fractional Seconds** and **Date & Time** fields in Point Cloud Data Packets strictly follow the PTP master device. Certain PTP master devices may have a specified offset from the lidar's time output. Please verify the configuration and calibration of your PTP master device.

B.2 Absolute time of the Point Cloud Data Packets

The absolute time of a Point Cloud Data Packet is $t_0 = t_s + t_{frac}$, where:

- t_s is the whole second part (see the **Date & Time** field).
- t_{frac} is the microsecond or nanosecond part (see the **UTC Fractional Seconds** field).

The definition of the above fields is in [Section 3.1.2.5 Tail](#).

B.3 Start time of each block

Given the absolute time of this Point Cloud Data Packet as t_0 , the start time of each block $t(m)$ can be calculated.

At each $t(m)$, the lidar saves the current azimuth into the current block's Azimuth field in the Point Cloud Data Packet; see [Section 3.1.2.3 Body](#).

(Unit: μs)

Single Return Mode

Block	Start time $t(m)$
Block 1	$t_0 + 9$
Block 2	$t_0 + 9 + 111.11$

Dual Return Mode

Block	Start time $t(m)$
Block 1 & Block 2	$t_0 + 9$

B.4 Firing Sequences

All channels are divided into four banks; see [Appendix A Channel distribution data](#).

Two Firing Sequences are defined below and are executed alternately (i.e. the next round of firing uses a different Firing Sequence from this round of firing).

Firing Sequence 1	Firing Sequence 2
Banks CDB fire; Bank A rests	Banks CDA fire, Bank B rests



The current Firing Sequence is indicated by the **Mode Flag** field in the Tail of the Point Cloud Data Packets; see [Section 3.1.2 Point cloud UDP data](#).

B.5 Firing time offset of each channel

In Block m , the absolute firing time of Channel n is:

$$t(m, n) = t(m) + \Delta t(n)$$

The firing time offsets $\Delta t(n)$ are listed in the firetime correction file of this lidar unit.

B.5.1 Firetime correction file

Purpose

Each lidar unit has a firetime correction file, which contains the firetime offset of each channel. Such offsets are used for:

- Point cloud data analysis (see [Section 3.1.4 Point cloud data analysis method](#))
- Point cloud display in PandarView 2

How to obtain this file

- Send PTC command 0xA9; see the TCP API Reference Manual.
- Export the file using PandarView 2; see the PandarView 2 User Manual.
- Ask Hesai technical support or your sales representative.

Data format

The CSV file is as follows.

- LoopNum is the number of Firing Sequences.
- "Loop1" and "Loop2" are the firing channels of Firing Sequences 1 and 2, respectively. The firing channels are listed in the ascending order of $\Delta t(n)$.
- "Firetime1" and "Firetime2" are the firing time offsets $\Delta t(n)$ (unit: μs), which are the same.
- The file contains 99 rows of effective data (3 header rows and 96 channel rows), appended by 32 all-zero rows (shown as ellipses in the table next page).

EEFF	1	1	
Horizontal Resolution Mode	1	LoopNum	2
Loop1	Firetime1	Loop2	Firetime2
99	0.6	65	0.6
65	1.456	99	1.456
35	2.312	1	2.312
102	3.768	72	3.768
72	4.624	102	4.624
38	5.48	8	5.48
107	6.936	73	6.936
73	7.792	107	7.792
43	8.648	9	8.648
110	10.104	80	10.104
80	10.96	110	10.96
46	11.816	16	11.816
115	13.272	81	13.272

B.5 Firing time offset of each channel

81	14.128	115	14.128
51	14.984	17	14.984
118	16.44	88	16.44
88	17.296	118	17.296
54	18.152	24	18.152
123	19.608	89	19.608
89	20.464	123	20.464
59	21.32	25	21.32
126	22.776	96	22.776
96	23.632	126	23.632
62	24.488	32	24.488
97	25.944	67	25.944
67	26.8	97	26.8
33	27.656	3	27.656
104	29.112	70	29.112
70	29.968	104	29.968
40	30.824	6	30.824
105	32.28	75	32.28
75	33.136	105	33.136
41	33.992	11	33.992
112	35.448	78	35.448
78	36.304	112	36.304

B.5 Firing time offset of each channel

48	37.16	14	37.16
113	38.616	83	38.616
83	39.472	113	39.472
49	40.328	19	40.328
120	41.784	86	41.784
86	42.64	120	42.64
56	43.496	22	43.496
121	44.952	91	44.952
91	45.808	121	45.808
57	46.664	27	46.664
128	48.12	94	48.12
94	48.976	128	48.976
64	49.832	30	49.832
98	51.288	68	51.288
68	52.144	98	52.144
34	53	4	53
103	54.456	69	54.456
69	55.312	103	55.312
39	56.168	5	56.168
106	57.624	76	57.624
76	58.48	106	58.48
42	59.336	12	59.336

B.5 Firing time offset of each channel

111	60.792	77	60.792
77	61.648	111	61.648
47	62.504	13	62.504
114	63.96	84	63.96
84	64.816	114	64.816
50	65.672	20	65.672
119	67.128	85	67.128
85	67.984	119	67.984
55	68.84	21	68.84
122	70.296	92	70.296
92	71.152	122	71.152
58	72.008	28	72.008
127	73.464	93	73.464
93	74.32	127	74.32
63	75.176	29	75.176
100	76.632	66	76.632
66	77.488	100	77.488
36	78.344	2	78.344
101	79.8	71	79.8
71	80.656	101	80.656
37	81.512	7	81.512
108	82.968	74	82.968

B.5 Firing time offset of each channel

74	83.824	108	83.824
44	84.68	10	84.68
109	86.136	79	86.136
79	86.992	109	86.992
45	87.848	15	87.848
116	89.304	82	89.304
82	90.16	116	90.16
52	91.016	18	91.016
117	92.472	87	92.472
87	93.328	117	93.328
53	94.184	23	94.184
124	95.64	90	95.64
90	96.496	124	96.496
60	97.352	26	97.352
125	98.808	95	98.808
95	99.664	125	99.664
61	100.52	31	100.52
0	0	0	0
...
0	0	0	0

Appendix C: Power supply requirements

C.1 Input voltage

To ensure that the input voltage U_{in} at the lidar's connector (see [Section 2.2 Electrical interface](#)) is between 9 to 32 V DC, check these specifications:

- U_s : Voltage of the power source
- U_{drop} : Voltage drop over the cable, from the power source to the lidar's connector

$$U_{in} = U_s - U_{drop}$$

C.1.1 Estimate the minimum source voltage

Use either the estimation formula or the lookup table.

Estimation formula

A conservative estimate is:

$$U_{source,min} = 9 + \frac{P_{peak,max}}{9} \cdot (R_1 + R_{2,max}) \approx (9.1 + 0.2L)$$

$U_{source,min}$	minimum source voltage (unit: V)
$P_{peak,max} = 35 \text{ W}$	Lidar's peak power consumption in all operating conditions
R_1	Cable resistance (unit: Ω)
$R_{2,max} = 20 \text{ m}\Omega$	Resistance of the lidar connector, excluding jumper cable assembly
L	Cable length (unit: m)



The wire gauge of the lidar's power wire should be ≤ 18 AWG.
For 18 AWG (24.7 Ω /km) wires, $R_1 = 0.05L$.

Lookup table

Cable length L	Minimum source voltage $U_{\sim\text{source, min}}$
2 m	9.5 V
5 m	10.1 V
7 m	10.5 V
10 m	11.1 V

C.1.2 Avoid overvoltage

When the lidar's input voltage approaches 32 V, make sure there is no additional overshoot in the external power system. Even a short period of overvoltage can cause irreversible damage to the lidar.

C.2 Input power

The lidar's peak power consumption is within 35 W in all operating conditions. It is recommended to provide at least 35 W input power and 4 A input current to the lidar.

Appendix D: Legal notice

Copyright © 2017-2026 Hesai Technology Co., Ltd.

All rights reserved. Use or reproduction of this manual in parts or its entirety in any form or by any means without the written authorization of Hesai is prohibited.

Hesai Technology makes no representations or warranties, either expressed or implied, with respect to the contents hereof and specifically disclaims any warranties, merchantability, or fitness for any particular purpose. Further, Hesai Technology reserves the right to revise this publication and to make changes from time to time in the contents hereof without obligation to notify any person of such revisions or changes.

HESAI and HESAI logo are registered trademarks of Hesai Technology. All other trademarks, service marks, and company names in this manual or on Hesai's official website are properties of their respective owners.

The software included in this product contains copyright that is registered under Hesai Technology. Any third party is not permitted, except as expressly permitted by the licensor or expressly required by applicable law, to decompile, reverse engineer, disassemble, modify, rent, lease, loan, distribute, sublicense, create derivative works based on the whole or any part of the software.

Hesai Product Warranty Service Manual is on the Warranty Policy page of Hesai's official website: <https://www.hesaitech.com/warranty-policy/>

Hesai Technology Co., Ltd.

Phone: +86 400 805 1233

Website: www.hesaitech.com

Address: Building A, Haisu Culture Plaza, Shanghai, China

Business Email: info@hesaitech.comService

Email: service@hesaitech.com