

HESAI

www.hesaitech.com

ATX

**Hybrid Solid-State Lidar
User Manual**

Classification: CO (Public)

Doc version: A07-en-260520

Table of Contents

■ About this manual	1
Access to this manual	1
Technical support	1
Legends and format	1
■ Safety notice	2
Special warnings	2
Operating environment	3
Personnel	5
Installation and operation	5
Repair	9
1 Introduction	10
1.1 Operating principle	10
1.2 Basic structure	11
1.3 Channel distribution	12
1.4 Specifications	13
2 Setup	17
2.1 Mechanical installation	17
2.1.1 Typical mounting structure	19
2.1.2 Requirements for counterparts	21
2.1.3 Requirements for mounting rigidity and modalities	22
2.1.4 Mounting position	23
2.1.5 Coordinate Systems	24
2.1.6 Necessity of thermal design optimization	25
2.2 Electrical interface	26
2.2.1 Pin Description	27

2.2.2 Connector use	28
2.2.3 Cables (Ethernet)	31
2.3 Connection box (optional)	32
2.3.1 Ports	35
2.3.2 Connection	37
2.4 Network settings on the host computer	39
2.4.1 In Windows	40
2.4.2 In Ubuntu	43
2.5 Tools	46
3 Data structure	47
3.1 Point Cloud Data Packet	48
3.1.1 Ethernet Header	48
3.1.2 UDP data	49
3.1.3 Ethernet tail	55
3.1.4 Point cloud data analysis method	56
4 Maintenance	58
5 Parameter interfaces	60
5.1 Network connection	60
5.2 Functional settings	61
5.3 Lidar info	61
Appendix A: Channel distribution data	62
A.1 Angular position and performance	62
A.1.1 Sorted by vertical angles	62
A.1.2 Sorted by RingID	69
A.2 Angle correction file	76
A.3 Angle correction calculation	79
A.3.1 Horizontal angle of the current firing channel	79

A.3.2 Vertical angle of the current firing channel	80
Appendix B: Absolute time of point cloud data	81
B.1 Source of absolute time	81
B.1.1 PTP as the clock source	81
B.2 Absolute time of the Point Cloud Data Packets	82
B.3 Start time of each block	82
B.4 Laser firing time of each channel	82
B.4.1 Firetime correction file	83
Appendix C: Nonlinear reflectivity mapping	85
Appendix D: Legal notice	92

■ About this manual

Please make sure to read through this user manual before your first use and follow the instructions herein when you operate the product. Failure to comply with the instructions may result in product damage, property loss, personal injuries, and/or a breach of warranty.

Access to this manual

To obtain the latest version, please do one of the following:

- Contact your sales representative of Hesai.
- Contact Hesai technical support at service@hesaitech.com.

Technical support

If your question is not addressed in this user manual, please contact us at:

- service@hesaitech.com
- <https://www.hesaitech.com/technical-support/>
- <https://github.com/HesaiTechnology>

Legends and format



Warnings: Instructions that must be followed to ensure safe and proper use of the product.



Notes: Additional information that may be helpful.

Names of data fields are in monospace font.

For example: `Distance` represents the Distance field.

■ Safety notice

- Please make sure to read through this safety notice and follow all the instructions and warnings. Failure to comply with the instructions and warnings may result in product damage, property loss, and/or personal injuries.
- Please check the certification information on the product's nameplate. If an agreement has been made not to present certification information on the nameplate, please follow the agreed-to arrangements.
- If you incorporate this lidar product into your product(s), you are required to provide this user manual (or access to this user manual) to the intended users of your product(s).
- This lidar product is intended as a component of an end product. The end-product supplier is responsible for assessing the risk of use in accordance with applicable standards and informing the intended user of safety-related information.
- Should there be other agreements with specific users, the other agreements shall apply.
- Before using a product, please confirm with Hesai the development maturity of the product in a timely manner. For products still in development, Hesai makes no warranty of non-infringement nor assumes any responsibility for quality assurance.

Special warnings

Laser safety

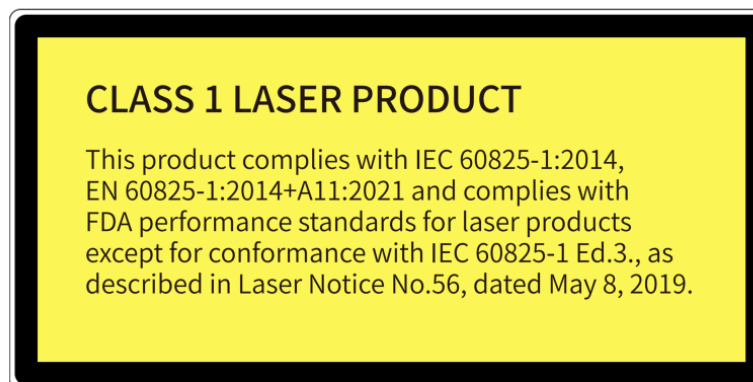

Hot surface



Hot parts!

Burned fingers when handling the parts.

Wait one-half hour after switching off before handling the parts.

Abnormalities

In any of the circumstances listed below, stop using the product immediately:

- If you suspect malfunctions of or damage to the product, with symptoms such as noticeable noise or vibration.
- If you or people in the nearby environment feel discomfort.
- If any device or equipment in the nearby environment malfunctions.

Meanwhile, contact Hesai or an authorized Hesai service provider for more information on product disposal.

Prohibition of disassembly

Unless expressly agreed to in writing by Hesai, do NOT disassemble the product.

Operating environment

Radio frequency (RF) interference

- Before using the product, make sure to read all the signs and notices on the product enclosure (including the nameplate). If specific users require not presenting certification information on the nameplate, please follow the agreed-to arrangements.
- Although the product is designed, tested, and manufactured to comply with the regulations on RF radiation (such as FCC, CE-EMC, or KCC), the radiation from the product may still influence electronic devices.

Vibration

- If significant mechanical shocks and vibration exist in the product's operating environment, please contact Hesai's technical support to obtain the shock and vibration limits of your product model. Exposure to over-the-limit shocks or vibration may damage the product.
- Make sure to package the product in shock-proof materials to avoid damage during transport.

Explosive atmosphere and other air conditions

- Do NOT use the product in any area where a potentially explosive atmosphere is present, such as where the air contains high concentrations of flammable chemicals, vapors, or particulates (including particles, dust, and metal powder).
- Do NOT expose the product to environments that have high concentrations of industrial chemicals, including liquefied gases that are easily vaporized (such as helium). Such exposure can damage or impair product functionality.

Chemical environment

Do NOT expose the product to corrosive or strong polar chemical environments (such as liquids or gases), including but not limited to strong acids, strong bases, esters, and ethers. This is to avoid damage to the product (including but not limited to water resistance failure).

Ingress protection (IP)

Please check the product's user manual for its IP rating (refer to [Section 1.4 Specifications](#)). Make sure to avoid any ingress beyond that rating.

Operating temperature

Please check the product's user manual for its operating temperature (refer to [Section 1.4 Specifications](#)). Make sure not to exceed the operating temperature range.

Recommended storage conditions

Please store the product in a dry and well-ventilated place. The recommended ambient temperature is $23 \pm 5^{\circ}\text{C}$, with relative humidity between 30% and 70% RH.

Light interference

Certain precision optical instruments may interfere with the laser light emitted from the product. Please check all the instructions for these instruments and take preventive measures if necessary. For example, protective leather covers are provided for certain product models; when these lidars are temporarily not used for measurement, the leather covers can be applied to block laser light emission.

Personnel

Recommended operator qualifications

The product should be operated by professionals with an engineering background or experience in operating optical, electrical, and mechanical instruments. Always follow the instructions in this manual throughout operation. If needed, please contact Hesai for technical support.

Medical device interference

- Some components in the product can emit electromagnetic fields. If the product operators or people in the nearby environment wear medical devices (such as cochlear implants, implanted pacemakers, and defibrillators), make sure to consult the physicians and medical device manufacturers for medical advice, such as determining whether a safe distance from the product is required.
- If you suspect that the product is interfering with your medical device, stop using the product immediately.

Installation and operation

Power supply

- Before powering on the product, make sure the electrical interfaces are dry and clean. Do NOT power on the product in a humid environment.
- Do NOT use damaged or out-of-spec cables or adapters.
- You are recommended to use only the cables and power adapters provided by Hesai. If you are to design, configure, or select the power supply system (including cables) for the product, make sure to comply with the electrical specifications in the product's user manual (refer to [Section 1.4 Specifications](#) and the Power Supply Requirements section if available); for technical support, please contact Hesai.
- Please check [Section 2.2 Electrical interface](#) and strictly follow the instructions on plugging/unplugging the connector. If abnormalities already exist (such as bent pins, broken cables, and loose threads), stop using the product and contact Hesai technical support.

Eye safety

The product is a Class 1 laser product. It satisfies the requirements of:

- IEC 60825-1:2014
- EN 60825-1:2014+A11:2021
- 21 CFR 1040.10 and 1040.11 except for deviations (IEC 60825-1 Ed.3) pursuant to Laser Notice No.56, dated May 8, 2019.

CAUTION: Use of controls or adjustments or performance of procedures other than those specified herein may result in hazardous radiation exposure.

CAUTION

- For maximum self-protection, it is strongly warned that users do NOT look into the transmitting laser through a magnifying product (microscope, eye loupe, magnifying glass, etc.).
- This product does not have a power switch. It starts operating once connected to power. During operation, the entire optical window can be regarded as the product's laser emitting window; looking at the optical window can be regarded as looking into transmitting laser.

Product enclosure

- Do NOT crush or puncture the product. If the product enclosure is broken, stop using it immediately and contact Hesai technical support.
- Certain product models contain high-speed rotating parts. To avoid potential injuries, do NOT operate the product if the enclosure is loose.
- If the product enclosure consists of fins or grooves, please wear gloves when handling the product. Applying too much pressure with your bare hands may cause cuts, bruises or other injuries.

Drops and burns

The product contains metal, glass, and plastic, as well as sensitive electronic components. If the product is dropped or burnt, stop using it immediately and contact Hesai technical support.

Optical window



The location of the optical window is illustrated in [Section 1 Introduction](#).

- Do NOT apply protective film, wax or any other substance on the optical window.
- To keep the product's optical window from fingerprints and other stains, do NOT touch the optical window with bare hands. If the optical window is already stained, please refer to the cleaning method in [Section 4 Maintenance](#).
- To prevent scratches, do NOT touch the product's optical window with hard or sharp objects. If scratches already exist, stop using the product and contact Hesai technical support. Severe scratches may affect the quality of the product's point cloud data.

Mounting

- Before operating the product, make sure it is properly and securely mounted. The mounting should prevent the product from leaving its mounting position under external forces (such as collisions, high winds, and stone impacts).
- If the product is installed in a cavity designed as a wet zone, make sure that no water accumulates in the cavity.
- Before installing any exterior part, please ensure that each exterior part and its movable area do not overlap the Field of View (FOV) of the lidar.



The lidar's FOV is the spatial angular range bounded by the horizontal and vertical FOV ranges (see [Section 1.4 Specifications](#)); the distance to the origin of the lidar's coordinate system is not limited. For inquiries about the FOV, please contact Hesai technical support.

Hot surface

During operation or the time period after the operation, the product's enclosure can be hot.

- To prevent discomfort or even burns, do NOT touch the product's enclosure with your skin.
- To prevent fires, make sure to keep flammable materials away from the product's enclosure.

Certain product models support active heating of the optical window to reduce the impact of ice and frost.

- While active heating is ON, the optical window can be hot. To prevent discomfort or even burns, avoid direct skin contact with the optical window.
- When the optical window is free of ice and frost, you may turn off active heating.

Peripherals

The product may be used along with accessories and devices, such as suction cup mounts, extension cables, power supplies, network devices, GNSS/PTP devices, CAN transceivers, and cleaning equipment.

When selecting a peripheral, please refer to all relevant specifications in the product's user manual or contact Hesai technical support. Using out-of-spec or unsuitable devices may result in product damage or even personal injuries.

Firmware and software upgrading

Make sure to use only the upgrade files provided by Hesai. Make sure to observe all the instructions provided for that upgrade file.

Customized firmware and software

- Before using a customized version of firmware and software, please fully understand the differences in functions and performance between the customized version and the standard version.
- Make sure to strictly follow all the instructions and safety precautions provided for that customized version. If the product does not function as anticipated, stop using the product immediately and contact Hesai technical support.

Point cloud data processing

- Certain product models support one or more point cloud data processing functions, including but not limited to: Noise Filtering, Interstitial Points Filtering, Retro Multi-Reflection Filtering, and Nonlinear Reflectivity Mapping.
- These functions are configurable and are intended only to assist the user in extracting information from the point cloud data. Users are in full control of whether to use any of these functions. Moreover, users are responsible for analyzing the product's intended application scenarios and evaluating the risk of enabling one or more of these functions in combination.
- To learn about the supported functions of a product model, please contact Hesai technical support.

Repair

- Unless expressly agreed to in writing by Hesai, do NOT disassemble, repair, modify, or alter the product by yourself or through any third party. Such a breach:
 - can result in product damage (including but not limited to water resistance failure), property loss, and/or injuries;
 - shall constitute a breach of warranty.
- For more product repair issues, please contact Hesai or an authorized Hesai service provider.

1 Introduction

1.1 Operating principle

Distance measurement: Time of Flight (ToF)

1. A laser diode emits a beam of ultrashort laser pulses onto the target object.
2. The laser pulses are reflected after hitting the target object. The returning beam is detected by an optical sensor.
3. Distance to the object can be accurately measured by calculating the time between laser emission and receipt.

$$d = \frac{ct}{2}$$

d: Distance

c: Speed of light

t: Travel time of the laser beam

1.2 Basic structure

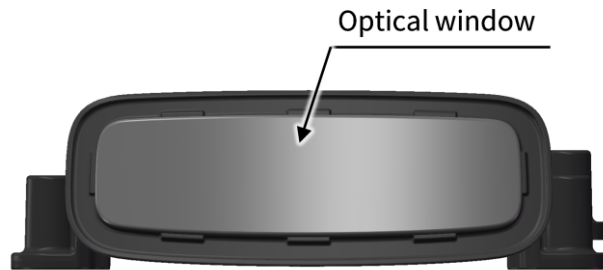

Figure 1. Front view

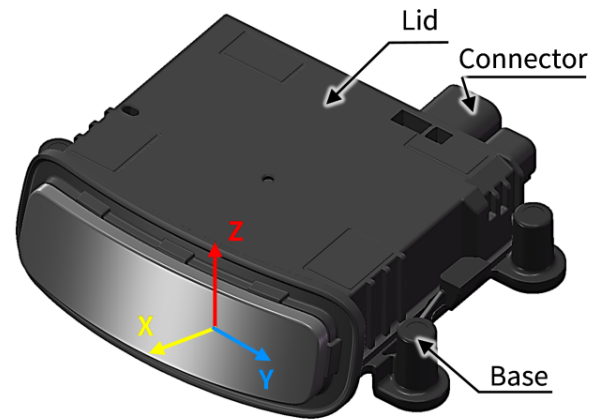

Figure 2. Coordinate system (isometric view)

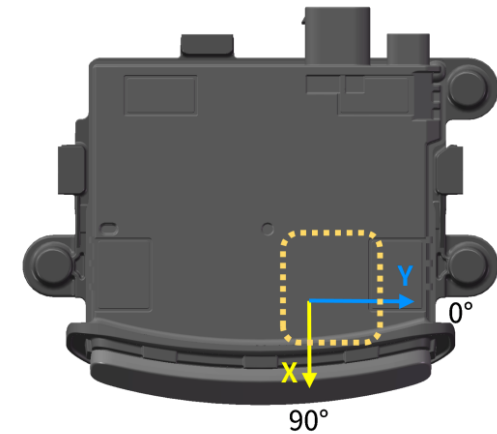

Figure 3. Top view

The lidar's coordinate system is illustrated in [Figure 2](#).

- Z-axis is the axis of rotation.
- The origin is shown in [Figure 5](#). All measurements are relative to the origin.

A scanning mirror is used for horizontal scanning, shown as the dotted box in [Figure 3](#).

The azimuth of the current firing channel is defined in [Figure 3](#). Y-axis corresponds to 0° .

1.3 Channel distribution

As shown in [Figure 4](#) and detailed in [Appendix A Channel distribution data](#), the laser channels are unevenly distributed.

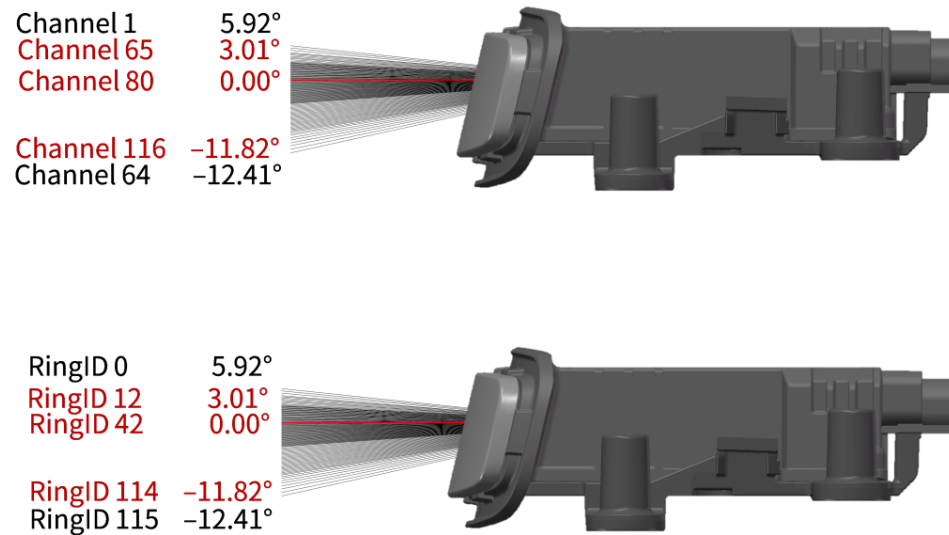

Figure 4. Channel vertical distribution (two sorting orders)

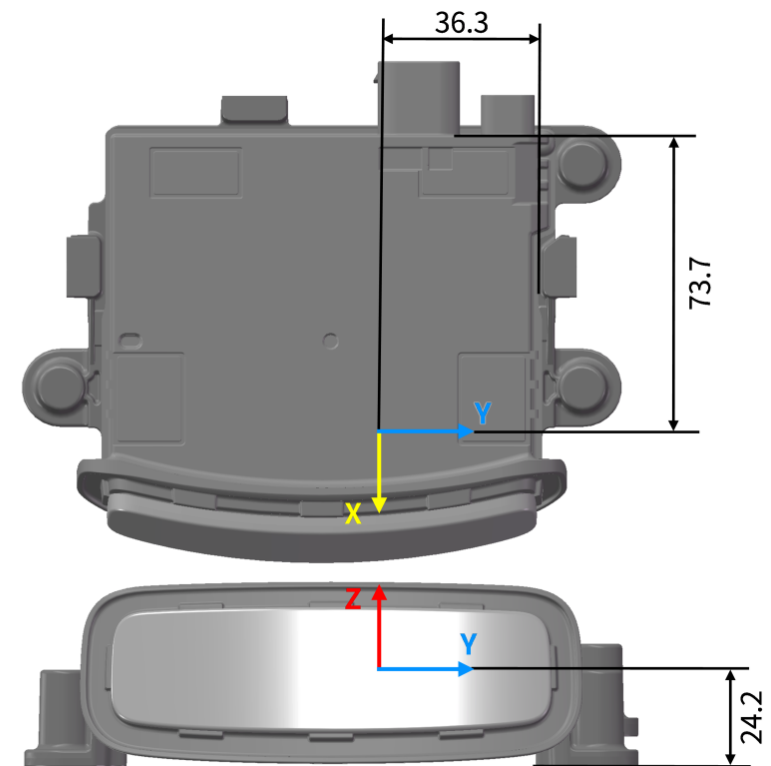

Figure 5. Origin of coordinates (unit: mm)

In [Figure 4](#):

- Channel number:
 - Counts from 1.
 - Normal channels (shown in black) and super-resolution channels (shown in red) are separately sorted in descending order of vertical angles.

- RingID:
 - Counts from 0.
 - All channels are sorted in descending order of vertical angles, corresponding to the channel numbers in the SDK for point cloud data analysis.

Each channel has an intrinsic angle offset, both horizontally and vertically. The offset angles are recorded in this lidar unit's angle correction file (see [Section A.2 Angle correction file](#)).

1.4 Specifications

SENSOR

Scanning method	1-D rotating mirror (hybrid solid-state)
Number of channels	116
Instrumented range	0.5 to 198 m
Ranging capability	1 to 200 m (at 10% reflectivity)
Ranging accuracy	±5 cm (typical)
Ranging precision	3 cm (1σ)
FOV (H × V)	120° × 18.3° (-12.4° to +5.9°)
ROI (H × V)	120° × 8.8° (-4.1° to +4.7°)
Horizontal resolution	0.08° (10 Hz)
Vertical resolution	ROI 0.1° Non-ROI Approx. 0.2°
Frame rate	10 Hz
Return mode	Single Return: Last/Strongest (default)

MECHANICAL/ELECTRICAL/OPERATIONAL

Wavelength	905 nm
Laser class	Class 1 Eye Safe
Ingress protection	IP6K7 & IP6K9K
Dimensions ①	102 × 102 × 30 (WDH, mm)
Rated voltage range ②	DC 9 to 16 V
Power consumption ③	10 W
Operating temperature ④	-40°C to 85°C
Storage temperature ④	-40°C to 105°C
Weight ①	355 g

DATA I/O

Data transmission	Automotive Ethernet, 100BASE-T1, slave mode
Measurements	Distance, azimuth angle, and reflectivity
Valid point rate ⑤	Single Return 1 740 000 points/sec
Point cloud data rate ⑥	Single Return 64.6/71.7 Mbps (avg/peak)
Total data rate ⑦	Single Return 66.0/73.3 Mbps (avg/peak)
Clock source	gPTP (802.1AS AUTOSAR)
PTP clock accuracy	≤10 μs
PTP clock drift ⑧	≤50 μs/s



Specifications are subject to change. Please refer to the latest version of this manual.

Notes to specifications

① Dimensions and weight

- May be different for customized models.
- The mechanical drawings and data exclusively provided for customized models shall prevail.

② Rated voltage range

Nominal voltage: 12 V

③ Power consumption

- Typical value, not including accessories such as the connection box.
- The external power supply should be able to provide at least 36 W.

④ Operating temperature and storage temperature

Both refer to ambient air temperature.

- During operation, the lidar's surface and internal temperatures may exceed the ambient air temperature.
- To obtain the real-time temperatures of the lidar's internal modules, refer to Get Lidar Status (0x09) in the TCP API Reference Manual.

⑤ Valid point rate

- Defined as the point cloud data points (number of returns) generated per second.
- In **Single Return Mode**:
 - Given: horizontal FOV (120°), horizontal resolution (0.08° at 10 Hz), number of channels (116), and frame rate (10 Hz).
 - At 10 Hz, each channel generates $120/0.08 = 1500$ points per frame; all channels generate $1500 \times 116 = 174\,000$ points per frame and 1 740 000 points (10 frames) per second.
- The actual horizontal FOV of each mirror surface is slightly larger than 120°, so the actual point rate is slightly more than the valid point rate.

⑥ Point cloud data rate

- In **Single Return Mode**:
 - Given: horizontal FOV (120°), horizontal resolution (0.08° at 10 Hz), frame rate (10 Hz), size of a Point Cloud Data Packet (1076 bytes) and the number of blocks in each packet (2)
 - At 10 Hz, one return is generated for each 0.08° azimuth; thus 1500 (120°/0.08°) returns for each frame and 15 000 returns (10 frames) per second.

- Each Point Cloud Data Packet contains two blocks, and each block stores one return.
- Therefore, $15\,000/2 = 7500$ packets are transmitted per second, totaling 7500×1076 bytes.
- With unit conversion, point cloud average data rate = $7500 \times 1076 \times 8 \times 1E-6 = 64.6$ Mbps.
- Because the duty cycle for point cloud data transmission is approximately 90%, the peak data rate is approximately 1.11 times the average data rate in the table.

⑦ **Total data rate**

Include additional Ethernet transmission overhead in the calculation.

⑧ **PTP clock drift**

Defined as the drift at a constant temperature after the lidar (slave clock) loses connection to the PTP master.

2 Setup

Before operating the lidar, strip away the transparent protective film on the optical window.



The information in this section may be different for customized models. The mechanical drawings and data exclusively provided for customized models shall prevail.

2.1 Mechanical installation

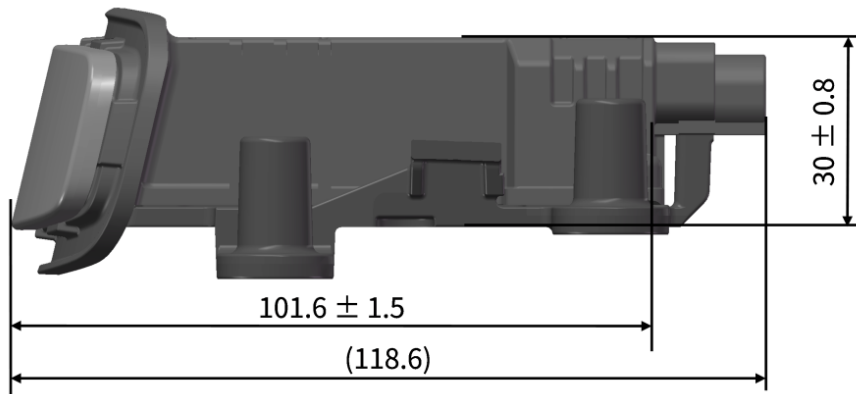

Figure 6. Right side view (unit: mm)

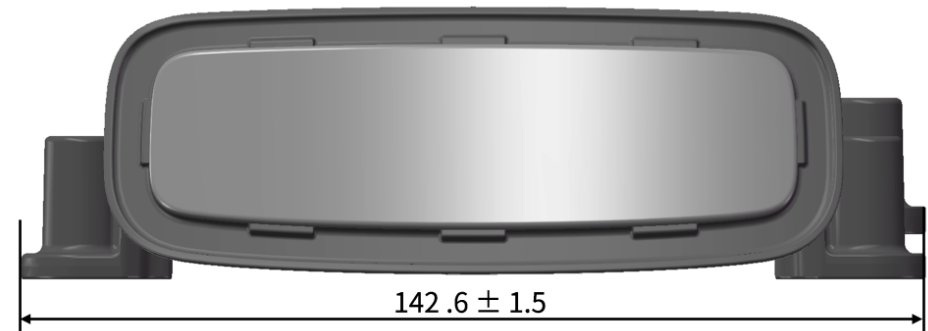

Figure 7. Front view (unit: mm)

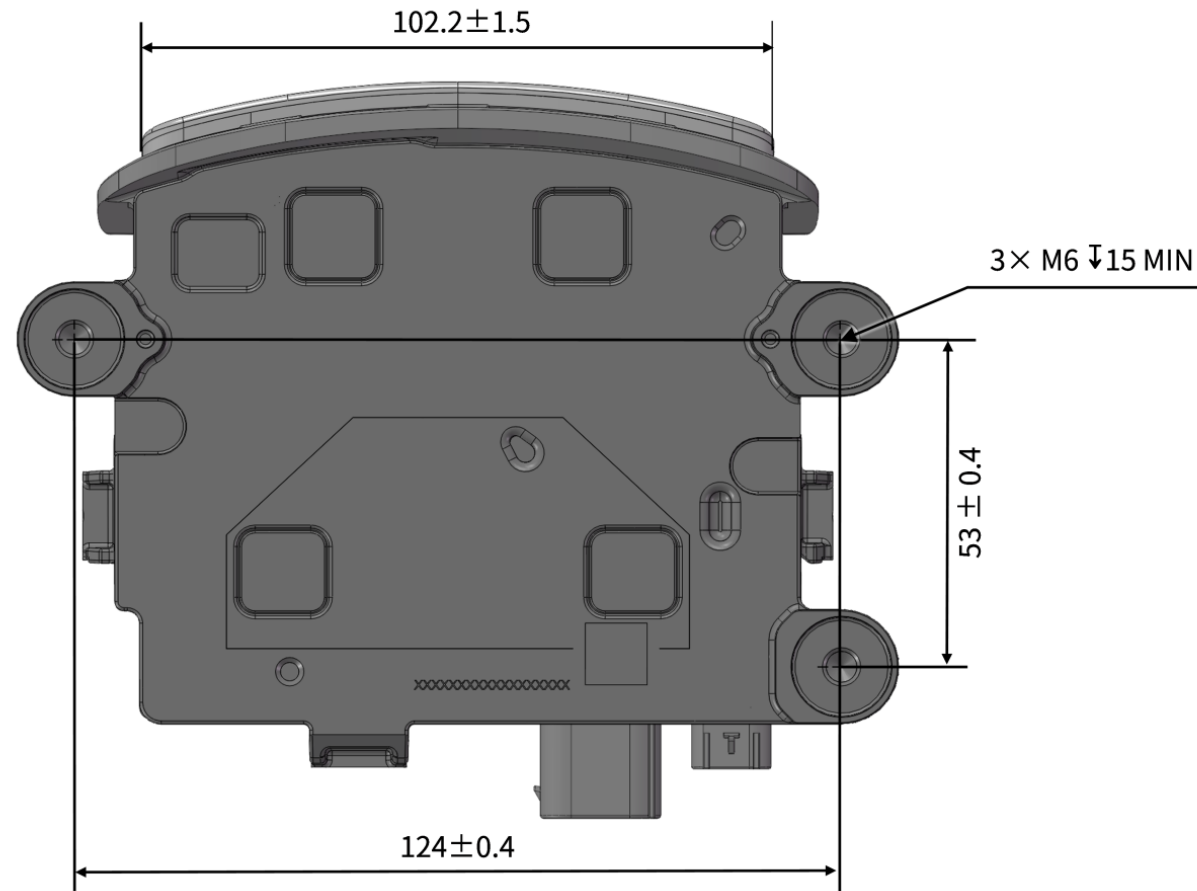

Figure 8. Bottom view (unit: mm)

2.1.1 Typical mounting structure

The lidar can be mounted using either screw holes or through holes on the lidar base.

- The number and positions of the mounting holes in [Figure 9](#) can be customized.
- The mounting scheme should not damage the lidar (including the screw threads).

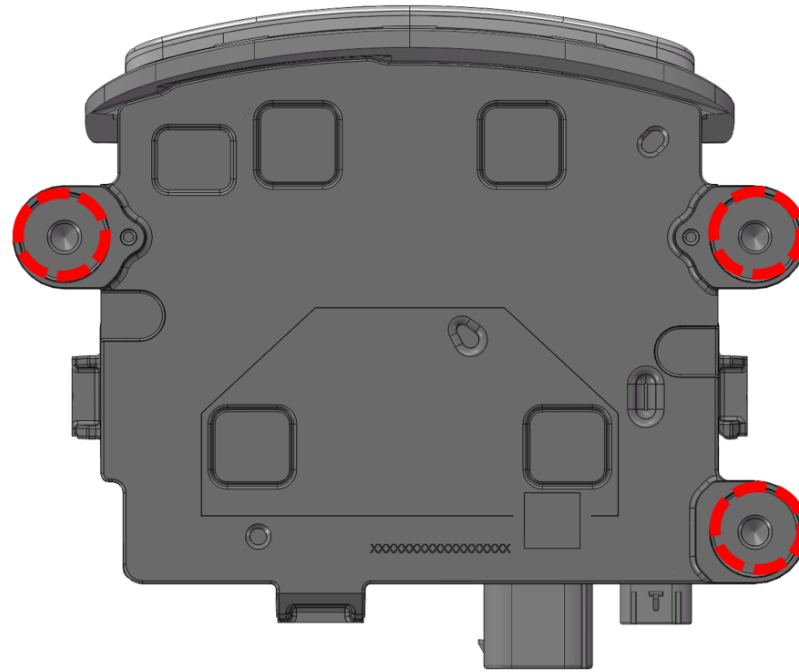

Figure 9. Mounting holes on lidar base

Use screw holes on the lidar base

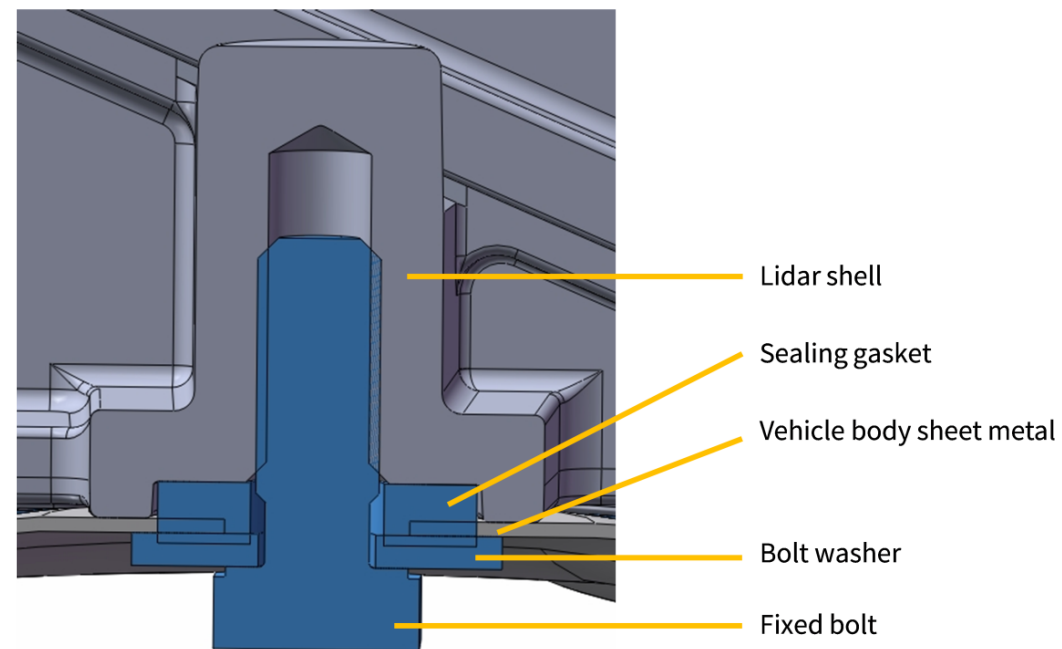

Figure 10. Screw structure

For carbon steel screws, the recommended parameters are as follows.

Screw specification	Screwing length (mm)	Number of screws
M5	≥ 9	≥ 3
M6	≥ 13	≥ 3



- Only use screws with a reliable thread-locking design.
- For screws with different materials or thread forms, the parameters should be adjusted.

Use through holes on the lidar base

For carbon steel screws, the recommended parameters are as follows:

Screw specification	Number of screws	Bolt performance rating
M4	3 to 4	≥ 8.8
M5		
M6		

2.1.2 Requirements for counterparts

Type of counterparts	Profile tolerance of the mounting surface
Plastic parts (such as the trim cover)	≤ 0.6
Sheet metal parts (such as the cross member)	≤ 0.6
Mounting brackets (such as a die-cast bracket)	≤ 0.2

2.1.3 Requirements for mounting rigidity and modalities

- Please provide the details of the mounting structure for Hesai's assessment, as any deviation in the mounting surface of the bracket may impair lidar performance.
- The mounting bracket should be stable and reliable. The impact of the mounting bracket on the vehicle's modal characteristics should be validated. This is to prevent NVH issues such as resonance.
- To prevent the impact of external forces, only connect the lidar at its mounting points. If any other part of the lidar needs to be connected, please confirm with Hesai in advance.
- When the lidar is installed on the counterpart, the installation structure, tolerances, and counterpart structural strength must be confirmed to ensure that the lidar will not deform.
- The minimum spacing between the lidar and its surrounding parts should be over 10 mm. This is to prevent the lidar from scraping and bumping during normal operation, mounting, and dismounting.
- To ensure optimal ROI performance, the mounting tolerances should be within $\pm 1.5^\circ$ in the direction of Y-axis (pitch angle) of the vehicle coordinate system (see [Figure 2. Coordinate system \(isometric view\)](#)).
- Contaminants on the optical window (such as snow or mud) can impair lidar performance. Active cleaning equipment for the optical window is recommended.
- If the cavity in which the lidar is mounted is designed as a wet area, make sure that water does not accumulate in this area.

2.1.4 Mounting position

- The lidar's FOV should not be obscured.
- The mounting height should be over 300 mm above the ground.

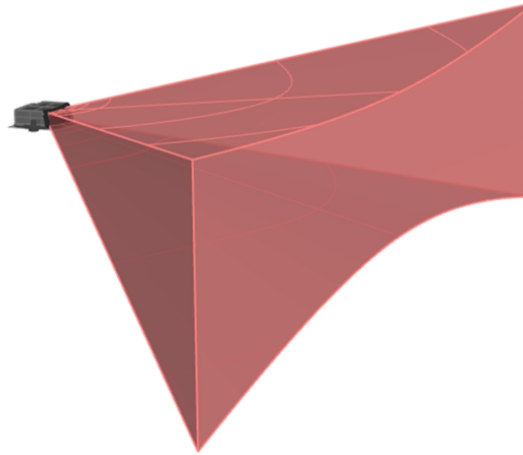

Figure 11. Lidar's FOV

2.1.5 Coordinate Systems

The coordinate systems of the lidar and vehicle are illustrated below.

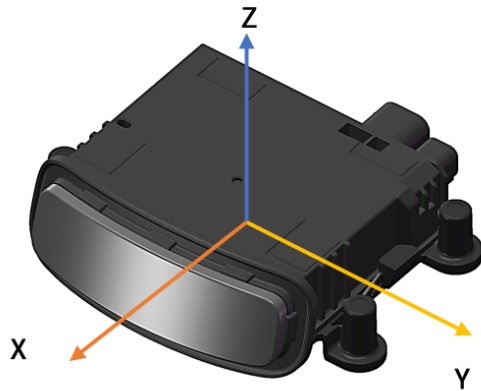

Figure 12. Lidar Coordinates

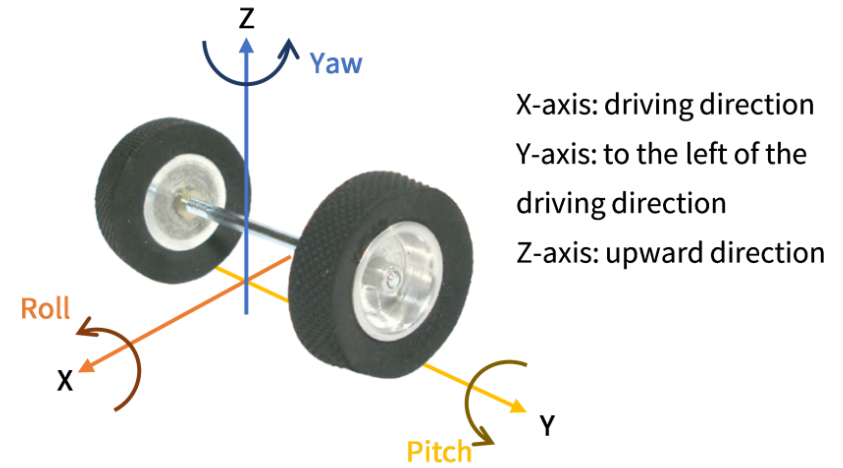

Figure 13. Vehicle coordinates

2.1.6 Necessity of thermal design optimization

The lidar's temperature performance is strongly correlated with three factors. With the first two factors predefined, the mounting scheme needs to be optimized to ensure that the lidar performs as expected under extreme operating conditions.

- Thermal characteristics of the lidar
- Environmental conditions in the vehicle's application scenario
- Mounting scheme

Yet the evaluation of thermal risks should not be carried out on the lidar alone — all the relevant thermal loads (the surrounding parts on the vehicle) and the mounting environment (such as the material of the mounting bracket) jointly affect the lidar's heat dissipation capability.

Therefore, systematic thermal design optimization is a necessary step in designing the lidar's mounting scheme. For more details, please contact Hesai's technical support.

2.2 Electrical interface

Automotive Ethernet

Standard automotive Ethernet interface as defined in Clauses B.1.4–B.1.6 of ISO 8092-6. See the left part of [Figure 14](#).

Power source

4 pin TE Connector. See the right part of [Figure 14](#).

Part Number: 114-18063-124 (male socket, on the lidar)

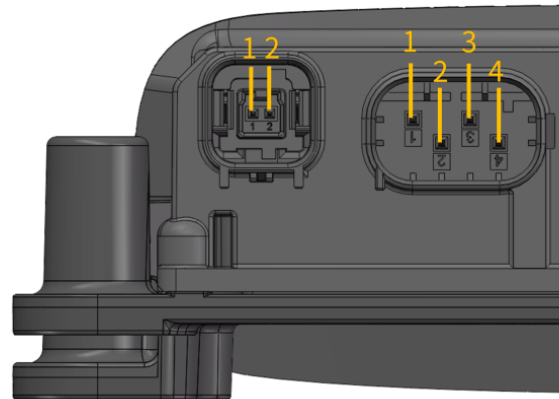

Figure 14. USCAR-compliant TE connectors

2.2.1 Pin Description

Interface	Pin number	Signal	Voltage
Automotive Ethernet	1	MDI-N	-
	2	MDI-P	-
Power source	1	VCC	9 to 16 V
	2	GND	-
	3	Reserved	-
	4	Reserved	-



Do NOT touch the reserved pins with bare hands.

2.2.2 Connector use

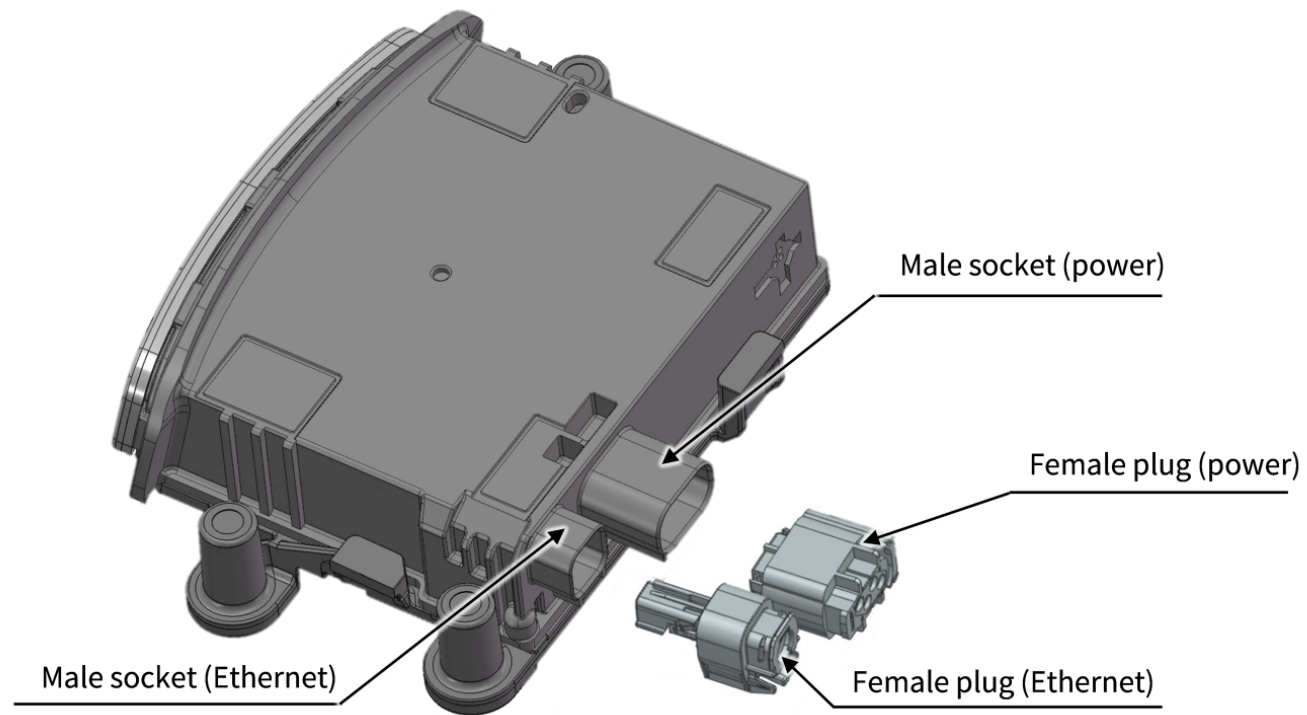

Figure 15. Connectors



- Before connection, check the pins on the socket and the holes on the plug. In case of bent pins or damaged holes, stop using the connector and contact technical support.
- To prevent breakdowns, turn off the power source before connection and disconnection.
- Do NOT attempt to force open a connection by pulling on the cables or by twisting the connectors in any way. Doing so can loosen the connectors' shells, or even damage the contacts.
- If the connector's shell is accidentally pulled off, stop using the connector and contact Hesai technical support. Do NOT attempt to assemble the connector's shell and cable collet; do NOT connect a connector without its shell. Doing so may damage the lidar's circuits.
- For further troubleshooting, please contact Hesai technical support or obtain work instructions from the connector manufacturer.
- The connector is designed to withstand at least **10** mating cycles; exceeding this number may increase the risk of connector damage.

Power connector

Connection	<ol style="list-style-type: none">1. Turn off the power source.2. Make sure the plug's CPA is on the same side as the socket's locking nose.3. Push the plug straight into the socket until you feel and hear a click.
Disconnection	<ol style="list-style-type: none">1. Depress the socket's locking nose.2. Pull the plug from the socket.

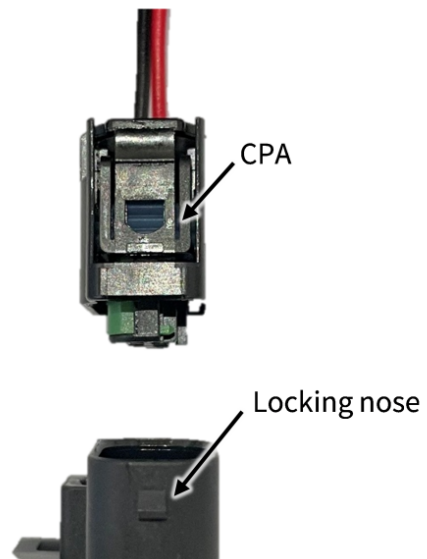

Figure 16. Power connection

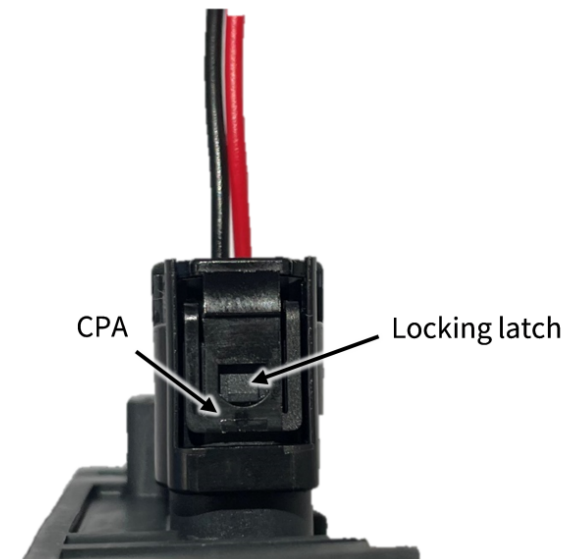

Figure 17. Power disconnection

Ethernet connector

Connection	<ol style="list-style-type: none"> 1. Turn off the power source. 2. Make sure the plug's locking latch matches the socket's slot. 3. Push the plug straight into the socket until you feel and hear a click.
Disconnection	<ol style="list-style-type: none"> 1. Depress the plug's locking latch. 2. Pull the plug from the socket.

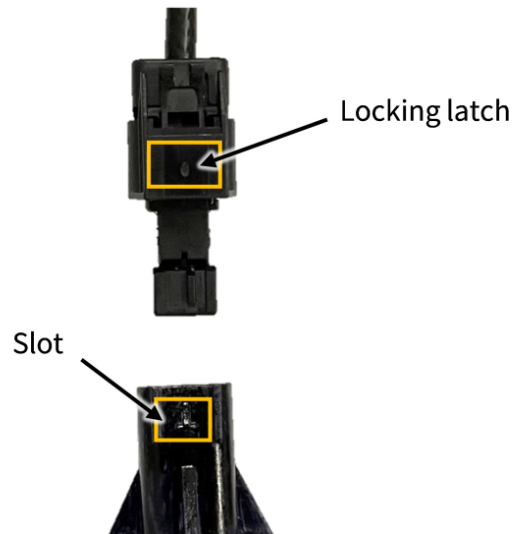

Figure 18. Ethernet connection



Figure 19. Ethernet disconnection

2.2.3 Cables (Ethernet)

Outer diameter (OD) = 4.10 ± 0.20 mm

Minimum bend radius:

- Single: $5 \times OD$
- Multiple: $15 \times OD$

2.3 Connection box (optional)

Users may connect the lidar with or without a connection box.

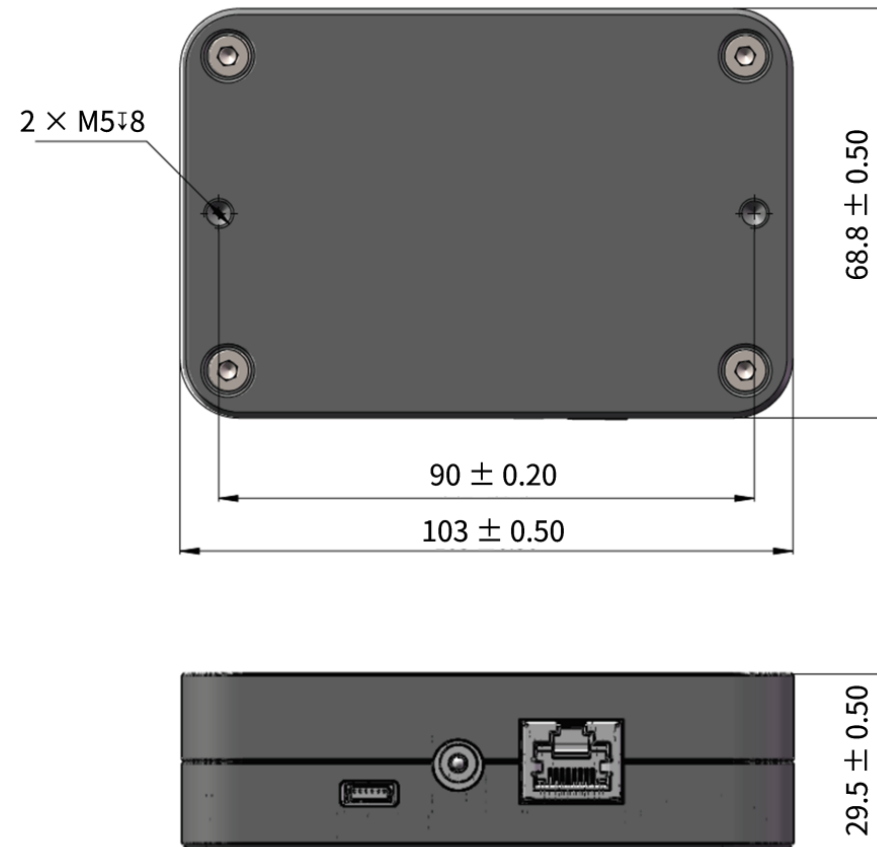

Figure 20. Connection box (unit: mm)

An additional cable is used for connecting the lidar (on the left) and the connection box (on the right), as shown below.



Each lidar can only use one cable because multiple cables cannot connect to each other.

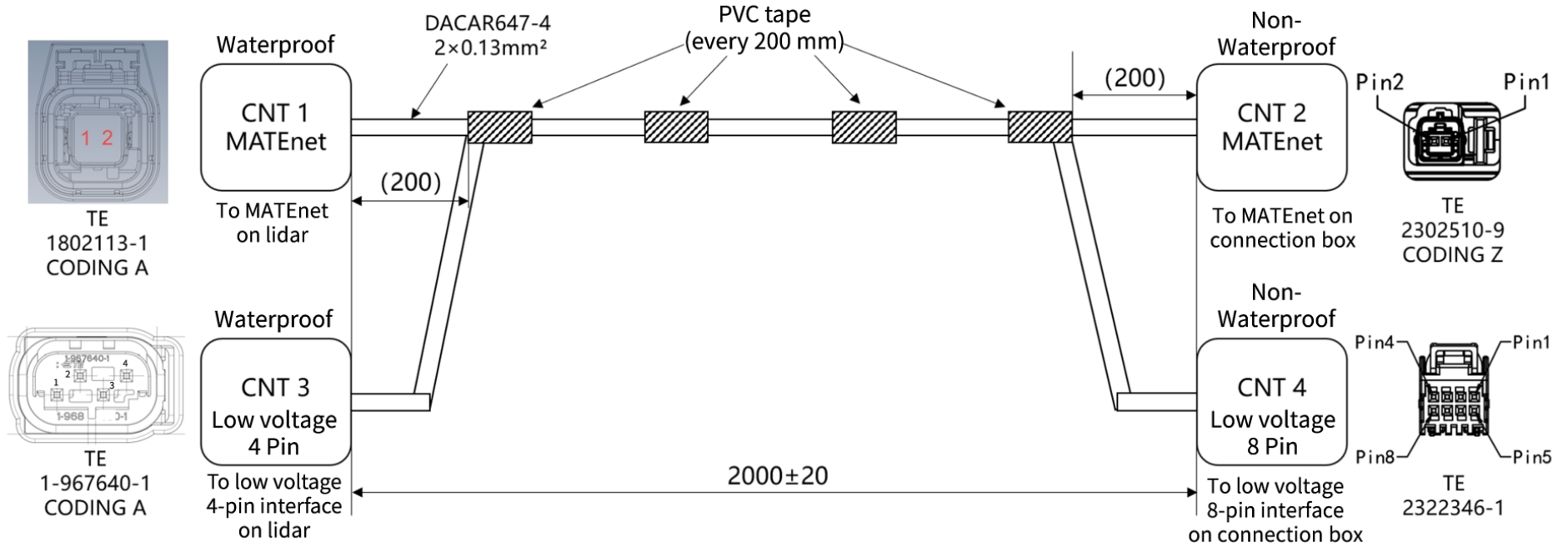

Figure 21. Cable between lidar and connection box (unit: mm)

The wire colors and cross-sectional areas are shown below:

Pin number on CNT1	Pin number on CNT2	Signal	Wire color	Wire cross section
2	1	MDI-P	Green	2 × 0.13 mm ²
1	2	MDI-N	White	
SHIELD	SHIELD	GND	Braided	
Pin number on CNT3	Pin number on CNT4	Signal	Wire color	Wire cross section
1	4	VCC	Red	0.75 mm ²
2	8	GND	Black	0.75 mm ²

2.3.1 Ports

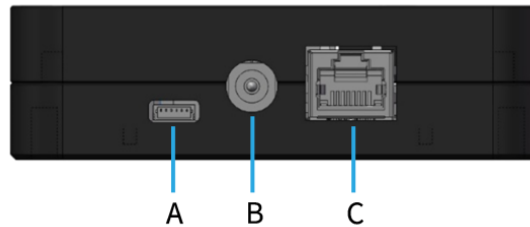

Figure 22. Connection box (front)

Port number	Port name	Description
A	Reserved port	Do Not touch or connect this port to external signals.
B	Power port	<p>Device-side connector: DC power jack</p> <ul style="list-style-type: none"> • Manufacturer: Same Sky Devices • Part Number: PJ-057AH • Reference drawing: https://www.sameskydevices.com/product/resource/pj-057a.pdf <p>Cable-side mating connector: DC barrel plug (DC-005 or equivalent)</p> <ul style="list-style-type: none"> • Outer diameter: 5.5 mm • Inner diameter: 2.1 mm • Insertion depth: 9.45 mm • Polarity: center positive
C	Standard Ethernet port	RJ45, 100 Mbps Ethernet

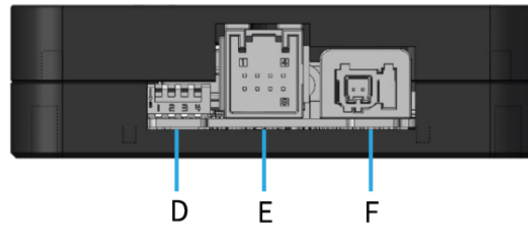

Figure 23. Connection box (back)

Port number	Port name	Description
D	Reserved port	Do NOT toggle or connect the DIP switches.
E	Power output port	See CNT4 in Figure 21 ; Part Number: 2311621-1.
F	Automotive Ethernet port	See CNT2 in Figure 21 ; Part Number: 2304372-1.

2.3.2 Connection

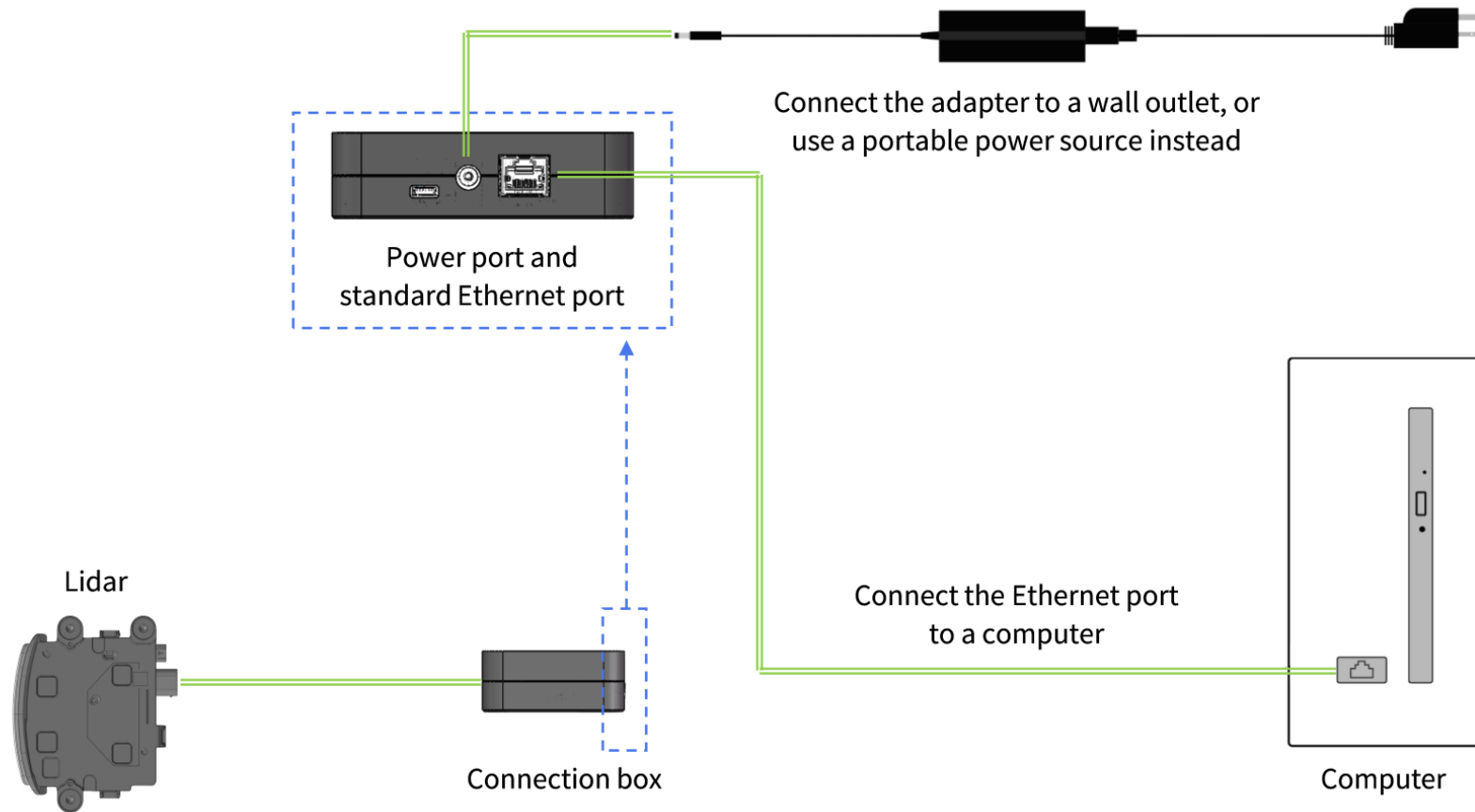

Figure 24. Connection with PTP (software simulation)

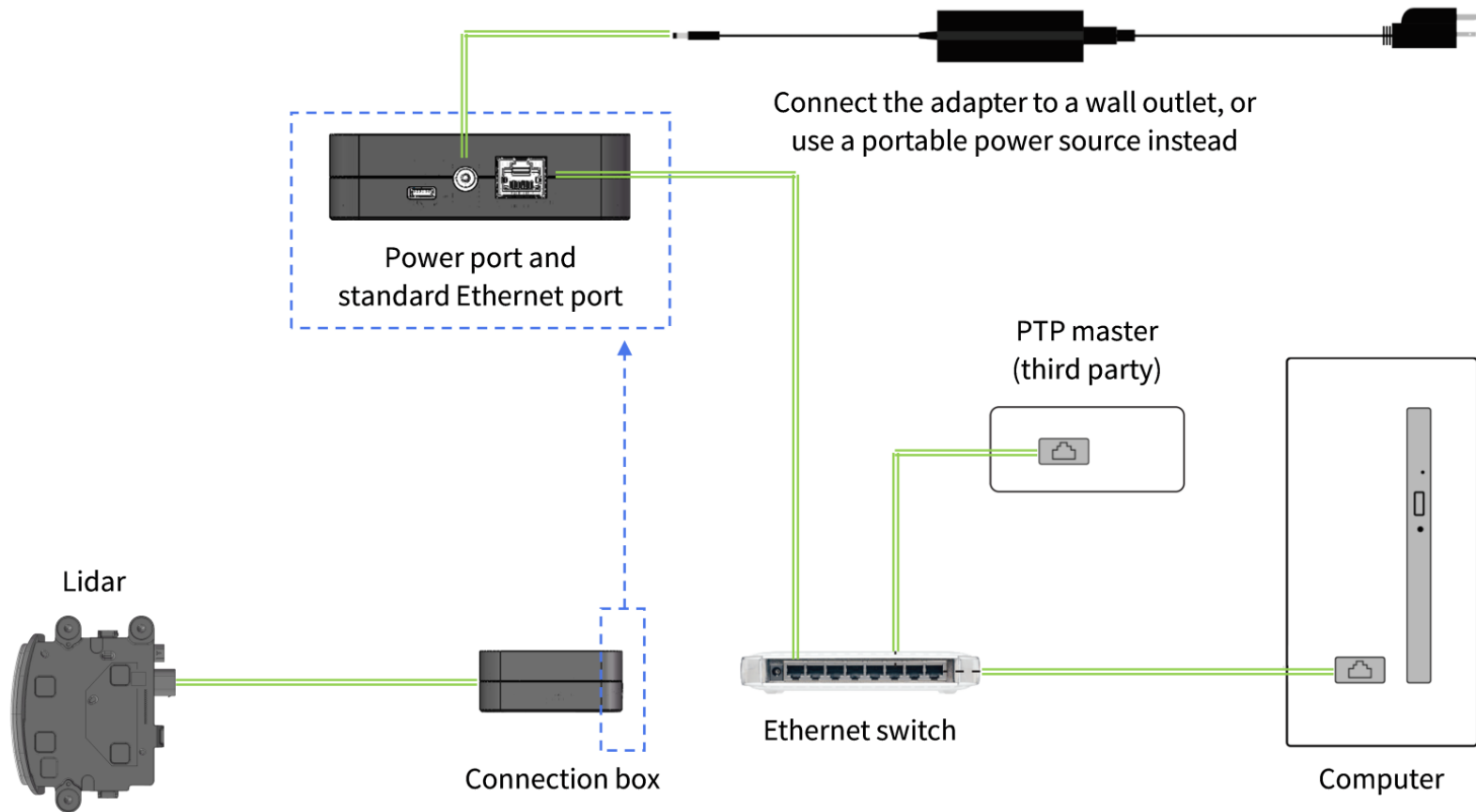

Figure 25. Connection with PTP (hardware device)

2.4 Network settings on the host computer

The lidar has no power switch. It starts transmitting data when both of these conditions are met:

- The lidar is connected to power.
- The lidar is connected to a host computer via Ethernet.

To analyze point cloud data, configure the network parameters of the host computer:

Network parameters	Value	Description
IP address	192.168.1.X	X can be selected from 2 to 200 and from 202 to 254.
Subnet mask	255.255.255.0	-
VLAN ID	Range: 1 to 4094	Required only when VLAN tagging is used. Make sure the host computer and the lidar use the same VLAN ID.

2.4.1 In Windows

1. [**Control Panel**] > [**Network and Internet**] > [**Network and Sharing Center**] > [**Change adapter settings**].
2. Right-click [**Ethernet**] or [**Ethernet X**] which shows Ethernet connection (with no red cross at the bottom left of the icon) > Select [**Properties**].

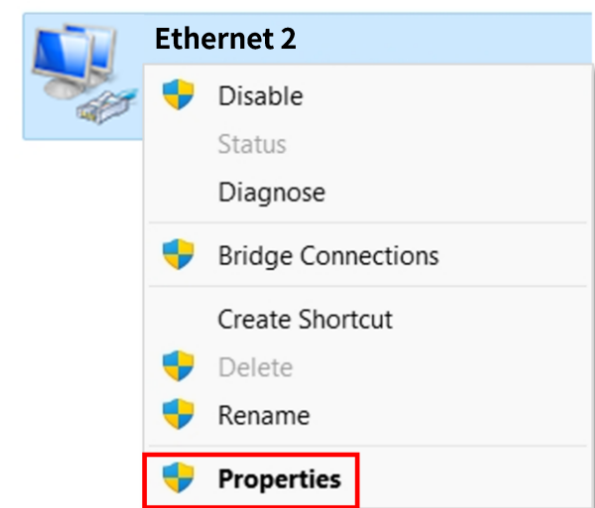
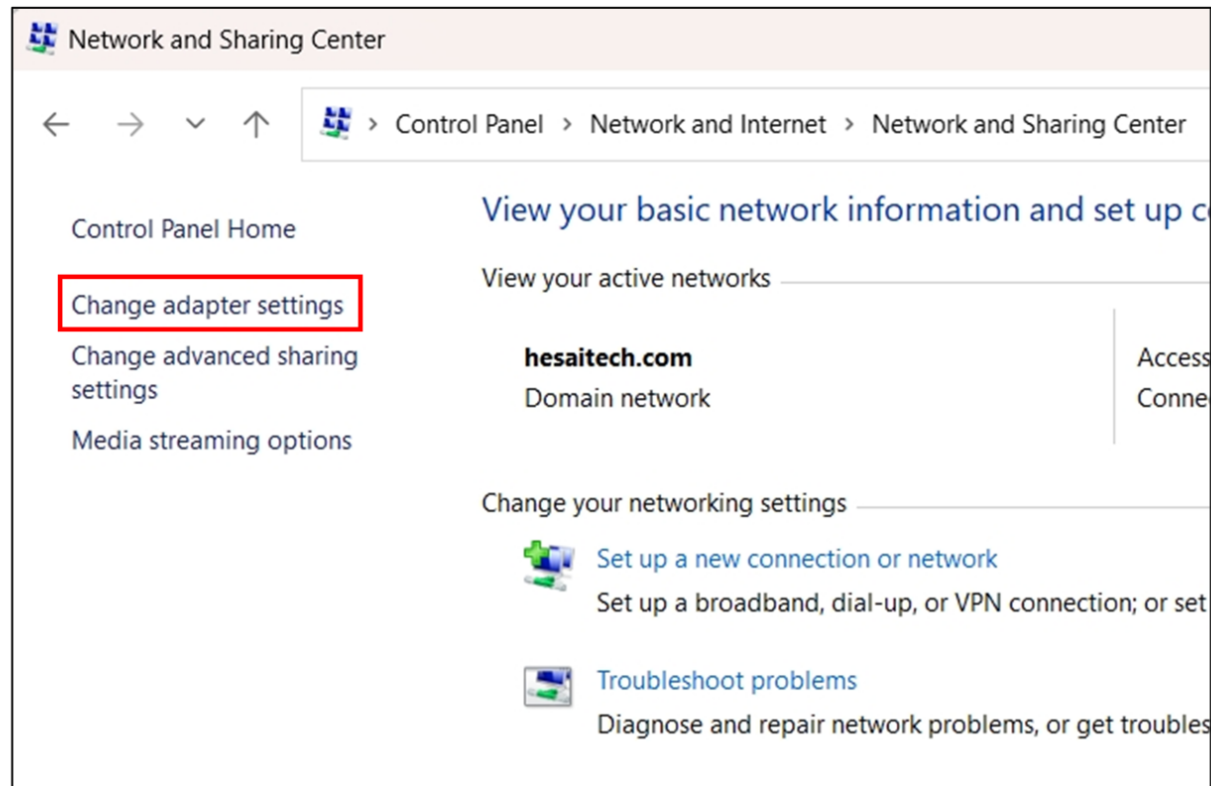

3. Double-click [**Internet Protocol Version 4 (TCP/IPv4)**].
4. Select [**Use the following IP addresses**] > Input the host computers's IP address and subnet mask.

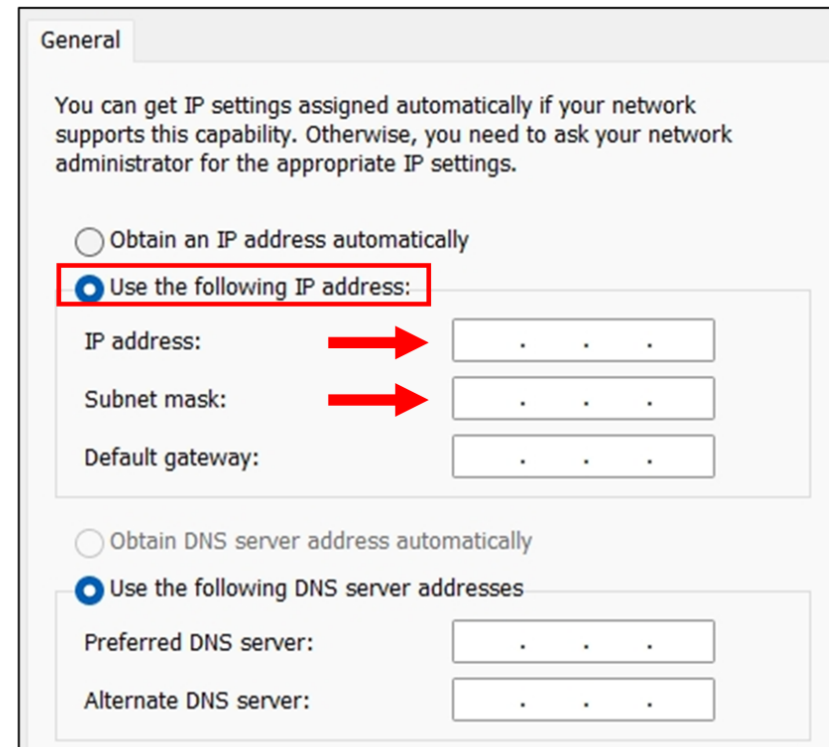
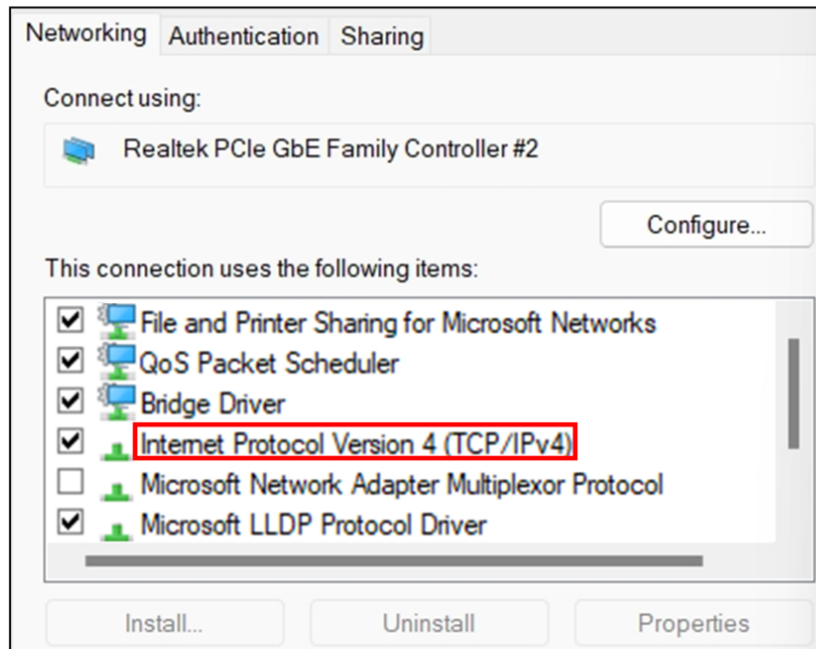

Ping command can be used to check the connection:



1. Press Win + R to open the Run dialog box.
2. Enter "cmd" and click [**OK**] to open the Command Prompt.
3. Enter "ping 192.168.1.201" and check the output.

5. To enable VLAN tagging:

Click [**Configure**] > Under the [**Advanced**] tag, select [**VLAN ID**] from the [**Property**] list > Input a VLAN ID in the [**Value**] box > Click [**OK**].

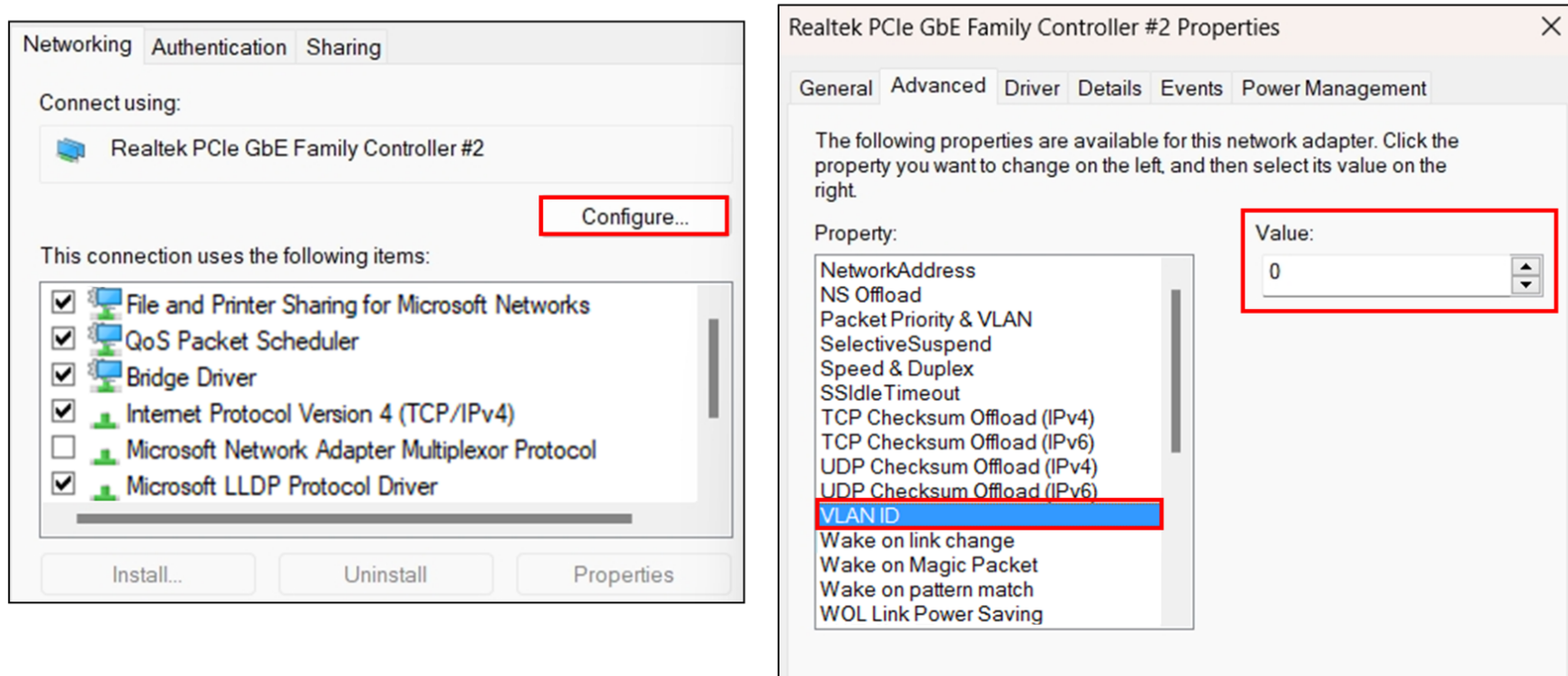

If the [**Property**] list has no [**VLAN ID**], it is recommended to update the network adapter driver.

2.4.2 In Ubuntu

1. Find the host computer's network interface name.

Method 1

- a. Open **Settings — Network**.
- b. Look for the interface whose status is "Connected".
The name in parentheses after "Ethernet" is the network interface name.



Method 2

- a. Open a terminal and run this command:

```
ifconfig
```

- b. Look for the interface with non-zero RX packets and bytes.
(In the example below, **enp5s0** shows non-zero Rx packets and bytes, indicating active data transmission.)

```
> ifconfig
docker0: flags=4099<UP,BROADCAST,MULTICAST> mtu 1500
  inet [REDACTED] netmask [REDACTED] broadcast [REDACTED]
  ether [REDACTED] txqueuelen 0 (Ethernet)
  RX packets 0 bytes 0 (0.0 B)
  RX errors 0 dropped 0 overruns 0 frame 0
  TX packets 0 bytes 0 (0.0 B)
  TX errors 0 dropped 0 overruns 0 carrier 0 collisions 0

enp2s0f0: flags=4099<UP,BROADCAST,MULTICAST> mtu 1500
  ether [REDACTED] txqueuelen 1000 (Ethernet)
  RX packets 0 bytes 0 (0.0 B)
  RX errors 0 dropped 0 overruns 0 frame 0
  TX packets 0 bytes 0 (0.0 B)
  TX errors 0 dropped 0 overruns 0 carrier 0 collisions 0

enp5s0: flags=4099<UP,BROADCAST,MULTICAST> mtu 1500
  ether [REDACTED] txqueuelen 1000 (Ethernet)
  RX packets 267706980 bytes 300970909734 (300.9 GB)
  RX errors 0 dropped 0 overruns 0 frame 0
  TX packets 3184 bytes 590575 (590.5 KB)
  TX errors 0 dropped 0 overruns 0 carrier 0 collisions 0
```

When not using VLAN

2. Run this command in the terminal:

```
sudo ifconfig ${interface_name} ${ip_addr}
```

- Replace `${interface_name}` with the host computer's network interface name.
- Replace `${ip_addr}` with the host computer's IP address.

When using VLAN

2. Run this command in the terminal:

```
sudo ip link add link ${interface_name} name ${interface_name}.${vlan_id} type vlan id ${vlan_id}
sudo ip link set up ${interface_name}.${vlan_id}
sudo ip addr add ${ip_addr}/24 dev ${interface_name}.${vlan_id}
ip addr show ${interface_name}.${vlan_id}
```

- Replace `${interface_name}` with the host computer's network interface name.
- Replace `${vlan_id}` with the host computer's VLAN ID.
- Replace `${ip_addr}` with the host computer's IP address.

2.5 Tools



- The following tools are supported by most models. Contact Hesai technical support to confirm applicability.
- For a customized model or an early prototype, contact Hesai technical support to confirm applicability.

Tool	Purpose	Where to find it
PandarView 2 (point cloud visualization software)	To record and display point cloud data.	Public versions (for selected models only): https://www.hesaitech.com/downloads/
LidarUtilities (software for host computers)	To set parameters, check device info and status, or upgrade firmware and software.	Contact Hesai technical support for details.
API		Contact Hesai technical support to confirm the applicable API type for this model (HTTP, PTC, or serial communication API) and obtain the corresponding technical documentation.
Software development kits (SDKs) and ROS drivers	To assist development.	Public versions (for selected models only): https://github.com/HesaiTechnology
Web control	To set parameters, check device info and status, or upgrade firmware and software.	If this model supports web control, see the "Web Control" section of this manual.

3 Data structure

Unless otherwise specified, all the multi-byte fields are unsigned values transmitted in little-endian format.

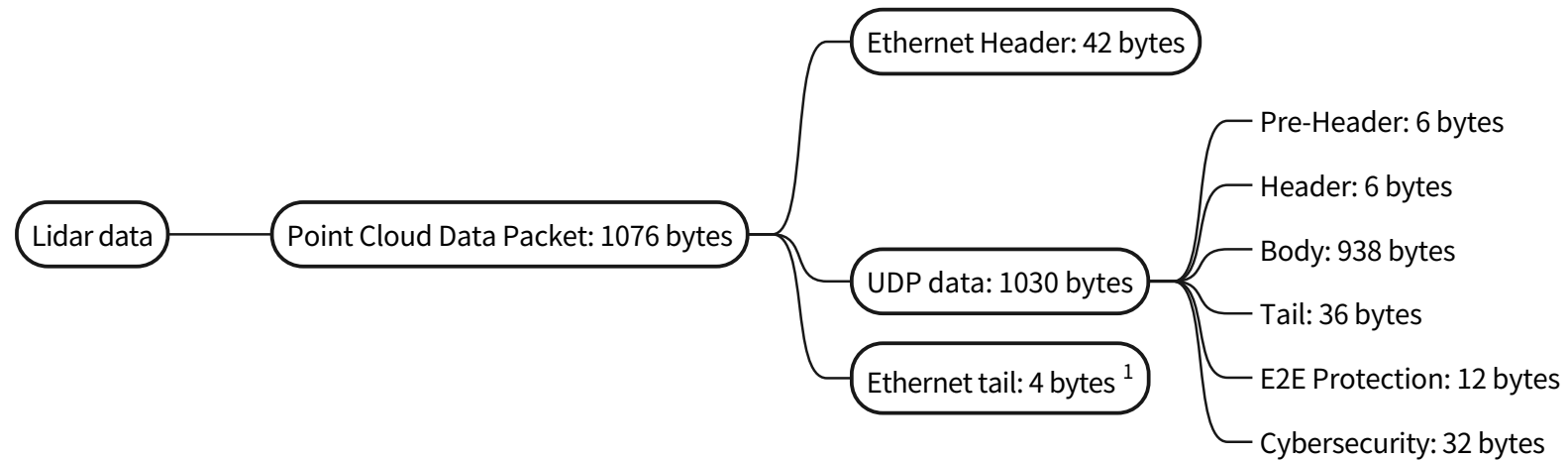

1. Network monitoring software (such as WireShark) usually does not display the **Ethernet tail** (4 bytes).

Figure 26. Data structure

3.1 Point Cloud Data Packet

Before receiving Point Cloud Data Packets, please perform [Network settings on the host computer](#).

3.1.1 Ethernet Header

Point Cloud Data Packet: Ethernet Header

Field	Byte(s)	Description
Ethernet II MAC	12	Destination MAC: xx:xx:xx:xx:xx:xx (FF:FF:FF:FF:FF:FF for broadcast) Source MAC: xx:xx:xx:xx:xx:xx
Ethernet Data Packet Type	2	0x08, 0x00
Internet Protocol	20	Protocol parameters
UDP Port Number	4	Source port (default: 10000) Destination port (default: 2368)
UDP Length	2	Eight bytes more than point cloud UDP data (see Figure 26. Data structure).
UDP Checksum	2	Checksum of the Ethernet Header

3.1.2 UDP data

Pre-Header

Field	Byte(s)	Description
Start of Packet	1	0xEE
Start of Packet	1	0xFF
Protocol Version Major	1	Main class of the point cloud UDP packet structure Current value: 0x04
Protocol Version Minor	1	Subclass of the point cloud UDP packet structure Current value: 0x07
Reserved	2	-







Header

Field	Byte(s)	Description
Channel Num	1	Number of channels Fixed: 0x74 (116)
Block Num	1	Number of block(s) per packet Fixed: 0x02 (2)
Reserved	1	-
Dis Unit	1	Unit of the Distance field. Fixed: 0x05 (5 mm)
Reserved	2	-

Body

Field	Byte(s)	Description
Azimuth 1	2	For Block 1: Current reference angle of the azimuth Unit: (1/256)°
Reserved	1	-
Block 1	464	For Block 1: Measurements made by each channel (starting from Channel 1); see Each block in the Body .
Azimuth 2	2	For Block 2: Current reference angle of the azimuth Unit: (1/256)°
Reserved	1	-
Block 2	464	For Block 2: Measurements made by each channel (starting from Channel 1).
CRC	4	CRC-32 checksum of the Body

Each block in the Body

Field	Byte(s)	Description												
Channel 1	4	Measurements of this channel												
		<table border="1"> <thead> <tr> <th>Field</th> <th>Byte(s)</th> <th>Description</th> </tr> </thead> <tbody> <tr> <td>Distance</td> <td>2</td> <td>Object distance = Distance × Dis Unit <div style="border: 1px dashed gray; padding: 5px; margin-top: 5px;">  Dis Unit is specified in Section 3.1.2.2 Header. </div> </td> </tr> <tr> <td>Reflectivity</td> <td>1</td> <td>Range: 0 to 255 Default: Linear reflectivity mapping (reflectivity value = Reflectivity Field × 1%) Also refer to Appendix C Nonlinear reflectivity mapping. <div style="border: 1px dashed gray; padding: 5px; margin-top: 5px;">  The mapping between this field and target reflectivity can be selected using PTC commands. </div> </td> </tr> <tr> <td>IPE Flags</td> <td>1</td> <td>IPE (Intelligent Point Cloud Engine) flags. Used to provide extra point cloud information for the application system to process point cloud data. See: IPE Flags. </td> </tr> </tbody> </table>	Field	Byte(s)	Description	Distance	2	Object distance = Distance × Dis Unit <div style="border: 1px dashed gray; padding: 5px; margin-top: 5px;">  Dis Unit is specified in Section 3.1.2.2 Header. </div>	Reflectivity	1	Range: 0 to 255 Default: Linear reflectivity mapping (reflectivity value = Reflectivity Field × 1%) Also refer to Appendix C Nonlinear reflectivity mapping . <div style="border: 1px dashed gray; padding: 5px; margin-top: 5px;">  The mapping between this field and target reflectivity can be selected using PTC commands. </div>	IPE Flags	1	IPE (Intelligent Point Cloud Engine) flags. Used to provide extra point cloud information for the application system to process point cloud data. See: IPE Flags .
		Field	Byte(s)	Description										
		Distance	2	Object distance = Distance × Dis Unit <div style="border: 1px dashed gray; padding: 5px; margin-top: 5px;">  Dis Unit is specified in Section 3.1.2.2 Header. </div>										
Reflectivity	1	Range: 0 to 255 Default: Linear reflectivity mapping (reflectivity value = Reflectivity Field × 1%) Also refer to Appendix C Nonlinear reflectivity mapping . <div style="border: 1px dashed gray; padding: 5px; margin-top: 5px;">  The mapping between this field and target reflectivity can be selected using PTC commands. </div>												
IPE Flags	1	IPE (Intelligent Point Cloud Engine) flags. Used to provide extra point cloud information for the application system to process point cloud data. See: IPE Flags .												
Channel 2	4	Measurements of this channel												
...												
Channel 116	4	Measurements of this channel												

IPE Flags

Bit(s)	Description
Bits [7:4]	Discrete Noise Point Level Range: 0 to 15 The higher the value, the more likely this data point is a discrete noise point (e.g., rain, fog, dust, or exhaust fumes).
Bit [3]	Reserved
Bit [2]	Interstitial Points Flag 1 – Suspected interstitial points 0 – Normal data points <div data-bbox="398 624 2074 730" style="border: 1px dashed gray; padding: 5px;">  Definition of interstitial points: When a beam partially hits a front target's edge and further hits a rear target, the return signal can result in a false point located between both targets. </div>
Bit [1]	Blooming Point Flag 1 – Suspected blooming points 0 – Normal data points
Bit [0]	Point Cloud Enhancement Flag 1 – Data points with relatively low confidence (including extra ground lines) 0 – Normal data points

Tail

Field	Byte(s)	Description
Reserved	10	-
Parity Flag	1	<p>[7:1] reserved</p> <p>[0] indicates whether this frame is an odd/even frame: 0 — Even frame (the scanning mirror rotates in the direction of increasing azimuth) 1 — Odd frame (the scanning mirror rotates in the direction of decreasing azimuth)</p> <div style="border: 1px dashed gray; padding: 5px; margin-top: 10px;">  The clockwise direction in Figure 3. Top view is defined as the direction of increasing azimuth. </div>
Reserved	7	-
Motor Speed	2	<p>Spin rate of the motor</p> <p>Signed integer</p> <p>The clockwise direction (in the top view) is defined as positive.</p> <p>Unit: 0.125°/s</p>
UTC Fractional Seconds	4	<p>The microsecond part of the Coordinated Universal Time (UTC) of this data packet.</p> <p>Unit: μs</p> <p>Range: 0 to 999 999 μs (1 s)</p>
Return Mode	1	<p>0x37 — Strongest (default)</p> <p>0x38 — Last</p>
Factory Information	1	Fixed: 0x42

Field	Byte(s)	Description																		
Date & Time	6	<p>Whole second part of the Coordinated Universal Time (UTC) of this data packet</p> <p>The current time representation mode is indicated by the first byte:</p> <ul style="list-style-type: none"> • Non-zero: broken-down time • Zero: calendar time (default) <p>Broken-down time</p> <table border="1"> <thead> <tr> <th>Each byte</th> <th>Range (decimal)</th> </tr> </thead> <tbody> <tr> <td>Year (current year minus 1900)</td> <td>≥ 70</td> </tr> <tr> <td>Month</td> <td>1 to 12</td> </tr> <tr> <td>Day</td> <td>1 to 31</td> </tr> <tr> <td>Hour</td> <td>0 to 23</td> </tr> <tr> <td>Minute</td> <td>0 to 59</td> </tr> <tr> <td>Second</td> <td>0 to 59</td> </tr> </tbody> </table> <p>Calendar time (default)</p> <p>Transmitted in big-endian format.</p> <table border="1"> <tbody> <tr> <td>Byte 0</td> <td>Fixed: 0x00</td> </tr> <tr> <td>Bytes 1 to 5</td> <td>Number of seconds since the Unix epoch (1970-01-01 00:00:00 UTC)</td> </tr> </tbody> </table> <p> The absolute time of the Point Cloud Data Packets is defined in Appendix B Absolute time of point cloud data.</p>	Each byte	Range (decimal)	Year (current year minus 1900)	≥ 70	Month	1 to 12	Day	1 to 31	Hour	0 to 23	Minute	0 to 59	Second	0 to 59	Byte 0	Fixed: 0x00	Bytes 1 to 5	Number of seconds since the Unix epoch (1970-01-01 00:00:00 UTC)
Each byte	Range (decimal)																			
Year (current year minus 1900)	≥ 70																			
Month	1 to 12																			
Day	1 to 31																			
Hour	0 to 23																			
Minute	0 to 59																			
Second	0 to 59																			
Byte 0	Fixed: 0x00																			
Bytes 1 to 5	Number of seconds since the Unix epoch (1970-01-01 00:00:00 UTC)																			

Field	Byte(s)	Description
UDP Sequence	4	Sequence number of this UDP packet Range: 0 to 0xFF FF FF FF

E2E Protection

Transmitted in big-endian format:

Field	Byte(s)	Description
Packet Length	2	-
Counter	2	Sequence number of this UDP packet Range: 0 to 0xFF FF
Data ID	4	Default: 0x00 00 EF FE
CRC	4	Range: from Pre-Header to field Data ID Algorithm: AUTOSAR E2E Profile 4

Cybersecurity

Field	Byte(s)	Description
Reserved	32	-

3.1.3 Ethernet tail

Field	Byte(s)	Description
FCS	4	Frame check sequence

3.1.4 Point cloud data analysis method

Take **Channel 5** in **Block 2** as an example.

Analyze the vertical and horizontal angles of a data point

1. Calculate the vertical angle (v_angle) of **Channel 5** according to [Section A.3 Angle correction calculation](#).
 - 0° represents the horizontal direction.
 - The upward direction is defined as positive.
2. Calculate the horizontal angle (h_angle) of **Channel 5** according to [Section A.3 Angle correction calculation](#).
The 0° position is defined in [Figure 3. Top view](#).

Analyze the distance of a data point

Analyze the **Distance** field of **Channel 5** in **Block 2** according to [Each block in the Body](#).

Draw the data point in a spherical or rectangular coordinate system

In a spherical coordinate system, the vertical and horizontal angles are defined in the figure below.

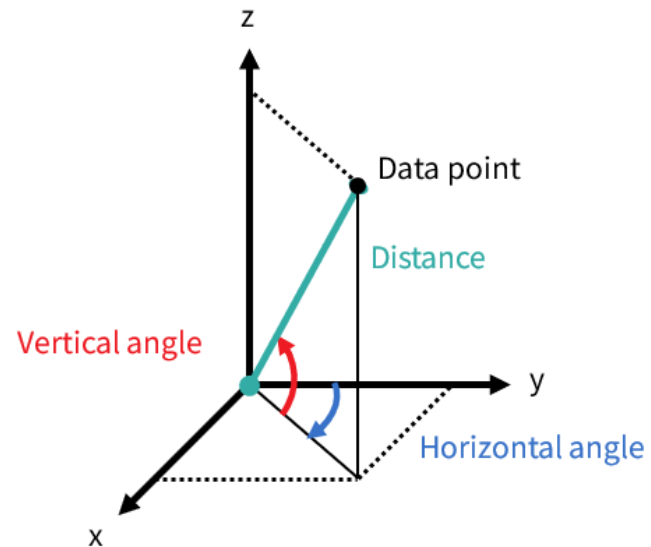

Obtain the real-time point cloud data by analyzing and drawing every data point in each frame.

4 Maintenance

The lidar's optical window is made of plastic (polycarbonate, PC), similar to the material used for car lamps.

- Do NOT wipe the optical window when it is dry, nor use abrasive cleaners. Doing so can damage the optical coating.
- Do NOT use organic cleaners, which can damage the optical window and even cause cracking.
 - Organic cleaners include but are not limited to tar removers, self-cleaning agents, adhesive removers, coating removers, foam cleaners, iron powder removers for car paint, glass cleaners, thinning agents, de-icers, paint surface treatment agents, alcohol, and vinegar.
 - If organic cleaners may be present when cleaning the equipment or performing related operations, please protect the optical window to prevent any contact with organic cleaners.
- Do NOT apply excessive force to the lidar, as this can damage the optical window.
 - If a pressure washer is used to clean the optical window, make sure the distance between the nozzle and the optical window remains at least 60 cm.
 - Using automatic cleaning devices that are not specifically designed for lidars may pose risks. Please contact Hesai technical support for assessment.
 - Do NOT use sharp objects (such as knives or metal tweezers) or hard brushes (such as stiff nylon brushes or wire brushes) to scratch the optical window cover surface. Such actions may damage the optical window surface, and in severe cases, may cause malfunction.
- After prolonged exposure to strong sunlight and high temperatures, the optical window should NOT be cleaned immediately.
- If snow or ice accumulates on the optical window, do NOT use a pressure washer or ice scraper.
 - A small broom is recommended to remove snow.
 - A solvent-free (i.e., free of organic solvents) ice removal spray is recommended to remove ice; alternatively, wait for the ice to melt by itself.
- Do NOT wax the optical window.



Please regularly check on the optical window, considering your use frequency, storage environment, and climate conditions.



- If foreign objects (such as dust, fingerprints, or oil stains) are found on the optical window, make sure to clean them.
- If corrosive foreign objects (such as insect remains, bird droppings, tree resin, road dust, industrial dust, asphalt, soot particles, and road salt) are found on the optical window, make sure to clean them immediately.

Cleaning procedure

1. Make sure the lidar is powered OFF.
2. Choose an appropriate cleaning agent:
 - For light stains, use room temperature water.
 - For heavier stains, use a mild soap solution (no more than two tablespoons of soap per quart or liter of water).
 - For stubborn stains, use a solvent-free (i.e., free of organic solvents), pH-neutral detergent at room temperature, such as car shampoo.
3. Take a clean soft sponge or anti-static microfiber cloth, dampen it with the chosen cleaning agent, and gently wipe the dirty area on the optical window back and forth.
4. For stubborn stains, cover the dirty area with the dampened sponge or cloth to soften the stains before wiping.
5. Immediately after removing the stains, rinse the optical window with clean water. Then, use a clean soft sponge or microfiber cloth to gently wipe away any remaining liquid (which may contain residual cleaning agents or contaminants).

5 Parameter interfaces

Except for [Section 5.1 Network connection](#), the other parameters in this section can be accessed using API.



5.1 Network connection

To obtain the network parameters (such as MAC address, IP address, and port numbers), please contact Hesai technical support.

Ethernet Communication Mode

Option(s)	Description
Slave	<p>Role of the lidar in automotive Ethernet communication.</p> <p>Since the lidar is in Slave mode, the host computer shall be in Master mode.</p>

VLAN

Option(s)	Description
Default: OFF VLAN ID: 1 to 4094	<p>VLAN tagging</p> <p>To enable VLAN tagging, use the same VLAN ID on both the lidar and the host computer.</p> <div style="border: 1px dashed gray; padding: 5px; margin-bottom: 10px;">  <ul style="list-style-type: none"> • Connection cannot be made if the lidar and the host computer use different VLAN IDs. • To minimize such risks, the VLAN ID in LidarUtilities is an invalid value (0 or 4095) by default. When checking the checkbox, users will be alerted to input a valid VLAN ID and restart the lidar; when unchecking the checkbox, the VLAN ID will default to the invalid value (0 or 4095). </div> <div style="border: 1px dashed gray; padding: 5px;">  <ul style="list-style-type: none"> • Once configured, VLAN ID will not change during firmware upgrades. • When VLAN is enabled, PTP connection will be lost; when VLAN is disabled, PTP connection will automatically recover. </div>

5.2 Functional settings

Return Mode

Option(s)	Description
Single Return: <ul style="list-style-type: none"> • Last • Strongest (default) 	The current return mode is shown in Point Cloud Data Packets; see the Return Mode field in Section 3.1.2.4 Tail .

5.3 Lidar info

Read-only parameter	Description
SN	Serial Number
PN	Part Number, indicating the lidar's hardware version Format: [Lidar Model]-[Configuration]
MAC address	Media access control (MAC) address Format: XX:XX:XX:XX:XX:XX (hexadecimal)

Angle correction file

Option(s)	Description
Get File	The angle correction file of each lidar unit is used to correct the azimuth and elevation of each channel.

Appendix A: Channel distribution data

A.1 Angular position and performance

Notes

Channel number	<ul style="list-style-type: none"> Counts from 1. Range in the descending order of the vertical angles of normal channels and super-resolution channels.
RingID	<ul style="list-style-type: none"> Counts from 0. Range in the descending order of the vertical angles of all channels, corresponding to the number in SDK when analyzing point cloud data.
Angular position	<p>Design values of each channel's horizontal (azimuth) angle offset and vertical (elevation) angle.</p> <ul style="list-style-type: none"> The accurate values are recorded in this lidar unit's angle correction file. To analyze point cloud data, refer to Section 3.1.4 Point cloud data analysis method.
Instrumented range	Actual measurement range, confined by the allocated Time of Flight (ToF) for each channel.

A.1.1 Sorted by vertical angles

Channel No.	Angular position (unit: °)			Instrumented range (unit: m)	
	Horiz. offset in even-numbered frames	Horiz. offset in odd-numbered frames	Vertical	Min	Max
1	0.82	0.82	5.92	0.5	90
2	0.82	0.82	5.52	0.5	90
3	0.82	0.82	5.12	0.5	90
4	0.82	0.82	4.72	0.5	120
5	-0.35	-0.35	4.52	0.5	120

Channel No.	Angular position (unit: °)			Instrumented range (unit: m)	
	Horiz. offset in even-numbered frames	Horiz. offset in odd-numbered frames	Vertical	Min	Max
6	-0.70	-0.70	4.32	0.5	120
7	-1.04	-1.04	4.12	0.5	120
8	-1.39	-1.39	3.91	0.5	150
9	-2.95	-2.95	3.71	0.5	150
10	0.54	0.54	3.51	0.5	198
11	-2.95	-2.95	3.31	0.5	198
12	0.54	0.54	3.11	0.5	198
13	-2.94	-2.94	2.90	0.5	198
14	0.54	0.54	2.71	0.5	198
15	-2.94	-2.94	2.50	0.5	198
16	0.54	0.54	2.30	0.5	198
17	2.94	2.94	2.10	0.5	198
18	-0.54	-0.54	1.90	0.5	198
19	2.94	2.94	1.70	0.5	198
20	-0.54	-0.54	1.50	0.5	198
21	2.94	2.94	1.30	0.5	198
22	-0.54	-0.54	1.10	0.5	198
23	2.94	2.94	0.90	0.5	198
24	-0.54	-0.54	0.70	0.5	198

Channel No.	Angular position (unit: °)			Instrumented range (unit: m)	
	Horiz. offset in even-numbered frames	Horiz. offset in odd-numbered frames	Vertical	Min	Max
25	-2.94	-2.94	0.50	0.5	198
26	0.54	0.54	0.30	0.5	198
27	-2.94	-2.94	0.10	0.5	198
28	0.54	0.54	-0.10	0.5	198
29	-2.94	-2.94	-0.30	0.5	150
30	0.54	0.54	-0.50	0.5	150
31	-2.94	-2.94	-0.70	0.5	150
32	0.54	0.54	-0.90	0.5	120
33	2.94	2.94	-1.10	0.5	120
34	-0.54	-0.54	-1.30	0.5	90
35	2.94	2.94	-1.50	0.5	90
36	-0.54	-0.54	-1.70	0.5	90
37	2.94	2.94	-1.90	0.5	60
38	-0.54	-0.54	-2.11	0.5	60
39	2.95	2.95	-2.31	0.5	60
40	-0.54	-0.54	-2.51	0.5	60
41	-2.95	-2.95	-2.71	0.5	60
42	0.54	0.54	-2.91	0.5	60
43	-2.95	-2.95	-3.11	0.5	60

Channel No.	Angular position (unit: °)			Instrumented range (unit: m)	
	Horiz. offset in even-numbered frames	Horiz. offset in odd-numbered frames	Vertical	Min	Max
44	0.54	0.54	-3.32	0.5	60
45	-2.95	-2.95	-3.52	0.5	60
46	0.54	0.54	-3.72	0.5	60
47	-2.95	-2.95	-3.92	0.5	60
48	0.54	0.54	-4.13	0.5	60
49	-0.54	-0.54	-4.53	0.5	60
50	-0.54	-0.54	-4.93	0.5	60
51	-0.54	-0.54	-5.33	0.5	60
52	-0.54	-0.54	-5.73	0.5	60
53	0.54	0.54	-6.12	0.5	60
54	0.54	0.54	-6.52	0.5	60
55	0.54	0.54	-6.92	0.5	60
56	0.54	0.54	-7.32	0.5	60
57	-0.54	-0.54	-7.70	0.5	60
58	-0.54	-0.54	-8.10	0.5	60
59	-0.54	-0.54	-8.51	0.5	60
60	-0.54	-0.54	-8.90	0.5	60
61	0.54	0.54	-9.46	4	60
62	0.53	0.53	-10.27	4	60

Channel No.	Angular position (unit: °)			Instrumented range (unit: m)	
	Horiz. offset in even-numbered frames	Horiz. offset in odd-numbered frames	Vertical	Min	Max
63	-0.54	-0.54	-11.23	4	60
64	-0.53	-0.53	-12.41	4	60
65	-2.95	0.54	3.01	-	-
66	-2.94	0.54	2.80	-	-
67	-2.94	0.54	2.60	-	-
68	-2.94	2.94	2.40	-	-
69	-2.94	2.94	2.20	-	-
70	-0.54	2.94	2.00	-	-
71	-0.54	2.94	1.80	-	-
72	-0.54	2.94	1.60	-	-
73	-0.54	2.94	1.40	-	-
74	-0.54	2.94	1.20	-	-
75	-0.54	2.94	1.00	-	-
76	-2.94	2.94	0.80	-	-
77	-2.94	2.94	0.60	-	-
78	-2.94	0.54	0.40	-	-
79	-2.94	0.54	0.20	-	-
80	-2.94	0.54	0.00	-	-
81	-2.94	0.54	-0.20	-	-

Channel No.	Angular position (unit: °)			Instrumented range (unit: m)	
	Horiz. offset in even-numbered frames	Horiz. offset in odd-numbered frames	Vertical	Min	Max
82	-2.94	0.54	-0.40	-	-
83	-2.94	0.54	-0.60	-	-
84	-2.94	2.94	-0.80	-	-
85	-2.94	2.94	-1.00	-	-
86	-0.54	2.94	-1.20	-	-
87	-0.54	2.94	-1.40	-	-
88	-0.54	2.94	-1.60	-	-
89	-0.54	2.94	-1.80	-	-
90	-0.54	2.95	-2.01	-	-
91	-0.54	2.95	-2.21	-	-
92	-2.95	2.95	-2.41	-	-
93	-2.95	2.95	-2.61	-	-
94	-2.95	0.54	-2.81	-	-
95	-2.95	0.54	-3.01	-	-
96	-2.95	0.54	-3.21	-	-
97	-2.95	0.54	-3.42	-	-
98	-2.95	0.54	-3.62	-	-
99	-2.95	0.54	-3.82	-	-
100	-2.95	0.54	-4.02	-	-

Channel No.	Angular position (unit: °)			Instrumented range (unit: m)	
	Horiz. offset in even-numbered frames	Horiz. offset in odd-numbered frames	Vertical	Min	Max
101	-2.95	0.54	-4.33	-	-
102	-0.54	0.54	-4.73	-	-
103	-0.54	-0.54	-5.13	-	-
104	-0.54	0.54	-5.53	-	-
105	-0.54	0.54	-5.93	-	-
106	-0.54	0.54	-6.32	-	-
107	0.54	0.54	-6.72	-	-
108	-0.54	0.54	-7.12	-	-
109	-0.54	0.54	-7.51	-	-
110	-0.54	0.54	-7.90	-	-
111	-0.54	-0.54	-8.31	-	-
112	-0.54	0.54	-8.71	-	-
113	-0.54	0.54	-9.18	-	-
114	-0.54	0.54	-9.87	-	-
115	-0.54	0.54	-10.75	-	-
116	-0.54	0.53	-11.82	-	-

A.1.2 Sorted by RingID

RingID	Angular position (unit: °)			Instrumented range (unit: m)	
	Horiz. offset in even-numbered frames	Horiz. offset in odd-numbered frames	Vertical	Min	Max
0	0.82	0.82	5.92	0.5	90
1	0.82	0.82	5.52	0.5	90
2	0.82	0.82	5.12	0.5	90
3	0.82	0.82	4.72	0.5	120
4	-0.35	-0.35	4.52	0.5	120
5	-0.70	-0.70	4.32	0.5	120
6	-1.04	-1.04	4.12	0.5	120
7	-1.39	-1.39	3.91	0.5	150
8	-2.95	-2.95	3.71	0.5	150
9	0.54	0.54	3.51	0.5	198
10	-2.95	-2.95	3.31	0.5	198
11	0.54	0.54	3.11	0.5	198
12	-2.95	0.54	3.01	-	-
13	-2.94	-2.94	2.90	0.5	198
14	-2.94	0.54	2.80	-	-
15	0.54	0.54	2.71	0.5	198
16	-2.94	0.54	2.60	-	-
17	-2.94	-2.94	2.50	0.5	198

RingID	Angular position (unit: °)			Instrumented range (unit: m)	
	Horiz. offset in even-numbered frames	Horiz. offset in odd-numbered frames	Vertical	Min	Max
18	-2.94	2.94	2.40	-	-
19	0.54	0.54	2.30	0.5	198
20	-2.94	2.94	2.20	-	-
21	2.94	2.94	2.10	0.5	198
22	-0.54	2.94	2.00	-	-
23	-0.54	-0.54	1.90	0.5	198
24	-0.54	2.94	1.80	-	-
25	2.94	2.94	1.70	0.5	198
26	-0.54	2.94	1.60	-	-
27	-0.54	-0.54	1.50	0.5	198
28	-0.54	2.94	1.40	-	-
29	2.94	2.94	1.30	0.5	198
30	-0.54	2.94	1.20	-	-
31	-0.54	-0.54	1.10	0.5	198
32	-0.54	2.94	1.00	-	-
33	2.94	2.94	0.90	0.5	198
34	-2.94	2.94	0.80	-	-
35	-0.54	-0.54	0.70	0.5	198
36	-2.94	2.94	0.60	-	-

RingID	Angular position (unit: °)			Instrumented range (unit: m)	
	Horiz. offset in even-numbered frames	Horiz. offset in odd-numbered frames	Vertical	Min	Max
37	-2.94	-2.94	0.50	0.5	198
38	-2.94	0.54	0.40	-	-
39	0.54	0.54	0.30	0.5	198
40	-2.94	0.54	0.20	-	-
41	-2.94	-2.94	0.10	0.5	198
42	-2.94	0.54	0.00	-	-
43	0.54	0.54	-0.10	0.5	198
44	-2.94	0.54	-0.20	-	-
45	-2.94	-2.94	-0.30	0.5	150
46	-2.94	0.54	-0.40	-	-
47	0.54	0.54	-0.50	0.5	150
48	-2.94	0.54	-0.60	-	-
49	-2.94	-2.94	-0.70	0.5	150
50	-2.94	2.94	-0.80	-	-
51	0.54	0.54	-0.90	0.5	120
52	-2.94	2.94	-1.00	-	-
53	2.94	2.94	-1.10	0.5	120
54	-0.54	2.94	-1.20	-	-
55	-0.54	-0.54	-1.30	0.5	90

RingID	Angular position (unit: °)			Instrumented range (unit: m)	
	Horiz. offset in even-numbered frames	Horiz. offset in odd-numbered frames	Vertical	Min	Max
56	-0.54	2.94	-1.40	-	-
57	2.94	2.94	-1.50	0.5	90
58	-0.54	2.94	-1.60	-	-
59	-0.54	-0.54	-1.70	0.5	90
60	-0.54	2.94	-1.80	-	-
61	2.94	2.94	-1.90	0.5	60
62	-0.54	2.95	-2.01	-	-
63	-0.54	-0.54	-2.11	0.5	60
64	-0.54	2.95	-2.21	-	-
65	2.95	2.95	-2.31	0.5	60
66	-2.95	2.95	-2.41	-	-
67	-0.54	-0.54	-2.51	0.5	60
68	-2.95	2.95	-2.61	-	-
69	-2.95	-2.95	-2.71	0.5	60
70	-2.95	0.54	-2.81	-	-
71	0.54	0.54	-2.91	0.5	60
72	-2.95	0.54	-3.01	-	-
73	-2.95	-2.95	-3.11	0.5	60
74	-2.95	0.54	-3.21	-	-

RingID	Angular position (unit: °)			Instrumented range (unit: m)	
	Horiz. offset in even-numbered frames	Horiz. offset in odd-numbered frames	Vertical	Min	Max
75	0.54	0.54	-3.32	0.5	60
76	-2.95	0.54	-3.42	-	-
77	-2.95	-2.95	-3.52	0.5	60
78	-2.95	0.54	-3.62	-	-
79	0.54	0.54	-3.72	0.5	60
80	-2.95	0.54	-3.82	-	-
81	-2.95	-2.95	-3.92	0.5	60
82	-2.95	0.54	-4.02	-	-
83	0.54	0.54	-4.13	0.5	60
84	-2.95	0.54	-4.33	-	-
85	-0.54	-0.54	-4.53	0.5	60
86	-0.54	0.54	-4.73	-	-
87	-0.54	-0.54	-4.93	0.5	60
88	-0.54	-0.54	-5.13	-	-
89	-0.54	-0.54	-5.33	0.5	60
90	-0.54	0.54	-5.53	-	-
91	-0.54	-0.54	-5.73	0.5	60
92	-0.54	0.54	-5.93	-	-
93	0.54	0.54	-6.12	0.5	60

RingID	Angular position (unit: °)			Instrumented range (unit: m)	
	Horiz. offset in even-numbered frames	Horiz. offset in odd-numbered frames	Vertical	Min	Max
94	-0.54	0.54	-6.32	-	-
95	0.54	0.54	-6.52	0.5	60
96	0.54	0.54	-6.72	-	-
97	0.54	0.54	-6.92	0.5	60
98	-0.54	0.54	-7.12	-	-
99	0.54	0.54	-7.32	0.5	60
100	-0.54	0.54	-7.51	-	-
101	-0.54	-0.54	-7.70	0.5	60
102	-0.54	0.54	-7.90	-	-
103	-0.54	-0.54	-8.10	0.5	60
104	-0.54	-0.54	-8.31	-	-
105	-0.54	-0.54	-8.51	0.5	60
106	-0.54	0.54	-8.71	-	-
107	-0.54	-0.54	-8.90	0.5	60
108	-0.54	0.54	-9.18	-	-
109	0.54	0.54	-9.46	4	60
110	-0.54	0.54	-9.87	-	-
111	0.53	0.53	-10.27	4	60
112	-0.54	0.54	-10.75	-	-

RingID	Angular position (unit: °)			Instrumented range (unit: m)	
	Horiz. offset in even-numbered frames	Horiz. offset in odd-numbered frames	Vertical	Min	Max
113	-0.54	-0.54	-11.23	4	60
114	-0.54	0.53	-11.82	-	-
115	-0.53	-0.53	-12.41	4	60

A.2 Angle correction file

Purpose

Each lidar unit has an angle correction file, which contains the corrected horizontal angles (azimuth) and vertical angles (elevation). Such corrections are used for:

- Point cloud data analysis (see [Section 3.1.4 Point cloud data analysis method](#))
- Point cloud display in PandarView 2

How to obtain this file

Use one of these ways:

- Send PTC command 0x05; see the TCP API Reference Manual.
- Export the file using PandarView 2; see the PandarView 2 User Manual.
- Ask Hesai technical support or your sales representative.

Data format

See table below.



- To inspect this .dat file, use a hex viewer.
- Byte size of the file: $181 + 6 \times N$
- Unless otherwise specified, all the multi-byte fields are transmitted in little-endian format.

Field	Byte(s)	Type	Description
Beginning of File	1	uint	0xEE
Beginning of File	1	uint	0xFF
Protocol Version Major	1	uint	Main class of the angle correction data structure Current value: 0x04
Protocol Version Minor	1	uint	Subclass of the angle correction data structure Current value: 0x03
Reserved	2	-	-
Channel Number	1	uint	Number of channels N Always 0x74 (116 channels)
Resolution	2	uint	Used in the units of the fields below. Default: 256
Even Azimuth Offset[0:N-1]	$2 \times N$	int16 array	Horizontal angle offset of each channel in an even-numbered frame Unit: $(1/\text{Resolution})^\circ$ <div style="border: 1px dashed gray; border-radius: 10px; padding: 5px; display: inline-block;">  Definition of even-numbered and odd-numbered frames: see the Parity Flag field in Section 3.1.2.4 Tail. </div>
Odd Azimuth Offset[0:N-1]	$2 \times N$	int16 array	Horizontal angle offset of each channel in an odd-numbered frame Unit: $(1/\text{Resolution})^\circ$
Elevation[0:N-1]	$2 \times N$	int16 array	Each channel's vertical angle Unit: $(1/\text{Resolution})^\circ$

Field	Byte(s)	Type	Description
Elevation_Adjust[0:69]	2 × 70	int16 array	Each channel's vertical angle adjustments for every 2° azimuth within the range of 20° to 160° (20°, 22°, 24°, ..., 158°) Unit: (1/Resolution)°  Given the azimuth (120°), only the adjustments within the range of vertical angle (30° to 150°) are valid.
SHA-256 Value	32	uint	SHA-256 hash of this angle correction file

A.3 Angle correction calculation

A.3.1 Horizontal angle of the current firing channel

$$h_{\text{angle}} = \alpha + \alpha_{\text{offset}}(\text{channel_id}) + \Delta t(\text{channel_id}) \cdot \omega$$

Current reference azimuth of this block (α)	See Azimuth 1 and Azimuth 2 in Section 3.1.2.3 Body .
Each channel's horizontal angle offset (α_{offset})	See angle correction file.
Each channel's firing time offset (Δt)	See Firetime correction file.
Motor speed (ω)	See Motor Speed in Section 3.1.2.4 Tail .

A.3.2 Vertical angle of the current firing channel

$$V_{\text{angle}} = \epsilon_{(\text{channel_id})} + \epsilon_{\text{adjust}}(\text{azimuth_id})$$

Each channel's vertical angle (ϵ)	See angle correction file.
Each channel's vertical angle adjustments for every 2° encoder angle (ϵ_{adjust})	See angle correction file.



If the encoder angle (α) is not divisible by 2°, the vertical angle adjustments (ϵ_{adjust}) should be linearly interpolated.

For example, if the ϵ_{adjust} for 50° and 52° encoder angles are c and d, respectively, then at the 51° encoder angle position, $\epsilon_{\text{adjust}} = (c + d)/2$.

Appendix B: Absolute time of point cloud data

B.1 Source of absolute time

The lidar retrieves the current absolute time by connecting to an external clock source.

B.1.1 PTP as the clock source

The lidar connects to a third-party PTP master to obtain PTP signal.



- PPS signal is not required nor used.
- PTP can be configured using LidarUtilities or PTC commands.
- The status of PTP signal can be found using LidarUtilities or PTC commands.

The absolute time is updated as follows:

PTP status	Date and time (accurate to the microsecond)	Lidar behavior
Free run	Virtual	Because the lidar has not been locked before, it starts counting from a virtual UTC (such as 2000-01-01 00:00:00) using the lidar's internal 1 Hz signal.
Tracking or Locked	Synchronized	The lidar extracts the actual date and time from the PTP master's messages.
Frozen	Drifting	When the lidar goes from Tracking/Locked to Frozen, it starts counting from the last synchronized time using the lidar's internal 1 Hz signal. This absolute time will gradually drift from the actual PTP time.



- PTP is a Plug & Play protocol; the lidar works as a PTP slave device and requires no additional setup.
- The **UTC Fractional Seconds** and **Date & Time** fields in Point Cloud Data Packets strictly follow the PTP master device. Certain PTP master devices may have a specified offset from the lidar's time output. Please verify the configuration and calibration of your PTP master device.

B.2 Absolute time of the Point Cloud Data Packets

The absolute time of a Point Cloud Data Packet is $t_0 = t_s + t_{frac}$, where:

- t_s is the whole second part (see the **Date & Time** field).
- t_{frac} is the microsecond or nanosecond part (see the **UTC Fractional Seconds** field).

The definition of the above fields is in [Section 3.1.2.4 Tail](#).

B.3 Start time of each block

Given the absolute time of this Point Cloud Data Packet as t_0 , the start time of each block $t(m)$ can be calculated.

At each $t(m)$, the lidar saves the current azimuth into the current block's Azimuth field in the Point Cloud Data Packet; see [Section 3.1.2.3 Body](#).

(Unit: μs)

Single Return mode

Block	Start time $t(m)$
Block 1	t_0
Block 2	$t_0 + \text{HRes}/\text{Motor Speed}$

For horizontal resolution (HRes), see [Section 1.4 Specifications](#).

For **Motor Speed**, see [Section 3.1.2.4 Tail](#).

B.4 Laser firing time of each channel

In Block m , the absolute firing time of Channel n is:

$$t(m, n) = t(m) + \Delta t(n)$$

The firing time offsets $\Delta t(n)$ are listed in the firetime correction file of this lidar unit.

B.4.1 Firetime correction file

Purpose

Each lidar unit has a firetime correction file, which contains the firetime offset of each channel. Such offsets are used for:

- Point cloud data analysis (see [Section 3.1.4 Point cloud data analysis method](#))
- Point cloud display in PandarView 2

How to obtain this file

- Send PTC command 0xA9; see the TCP API Reference Manual.
- Ask Hesai technical support or your sales representative.

Data format

See table below.



- To inspect this .dat file, use a hex viewer.
- Byte size of the file: $41 + 4 \times N$
- Unless otherwise specified, all the multi-byte fields are transmitted in little-endian format.

Field	Byte(s)	Type	Description
Start of Packet	1	uint	0xEE
Start of Packet	1	uint	0xFF
Protocol Version Major	1	uint	Main class of the firing time data structure Current value: 0x04
Protocol Version Minor	1	uint	Main class of the firing time data structure Current value: 0x01
Reserved	2	-	-

Field	Byte(s)	Type	Description
Channel Number	1	uint	Number of channels N Always 0x74 (116)
Firetime Unit	2	uint	Unit of Even Firetime and Odd Firetime Default: 1 (1 ns) Transmitted in big-endian format
Even Firetime[0:N-1]	2 × N	uint16 array	Firing time offset of each channel in an even-numbered frame Unit: Firetime Unit <div style="border: 1px dashed gray; border-radius: 10px; padding: 5px; display: inline-block;">  Definition of even-numbered and odd-numbered frames: see the Parity Flag field in Section 3.1.2.4 Tail. </div>
Odd Firetime[0:N-1]	2 × N	uint16 array	Firing time offset of each channel in an odd-numbered frame Unit: Firetime Unit
SHA-256 Value	32	uint	SHA-256 hash of this Firetime correction file

Appendix C: Nonlinear reflectivity mapping

By default, the **Reflectivity** field in Point Cloud Data Packets (see [Section 3.1.2.3 Body](#)) linearly represents target reflectivity.

Alternatively, users may choose the Nonlinear Mapping mode using LidarUtilities or PTC commands.

This mapping increases the contrast in the low-reflectivity region.

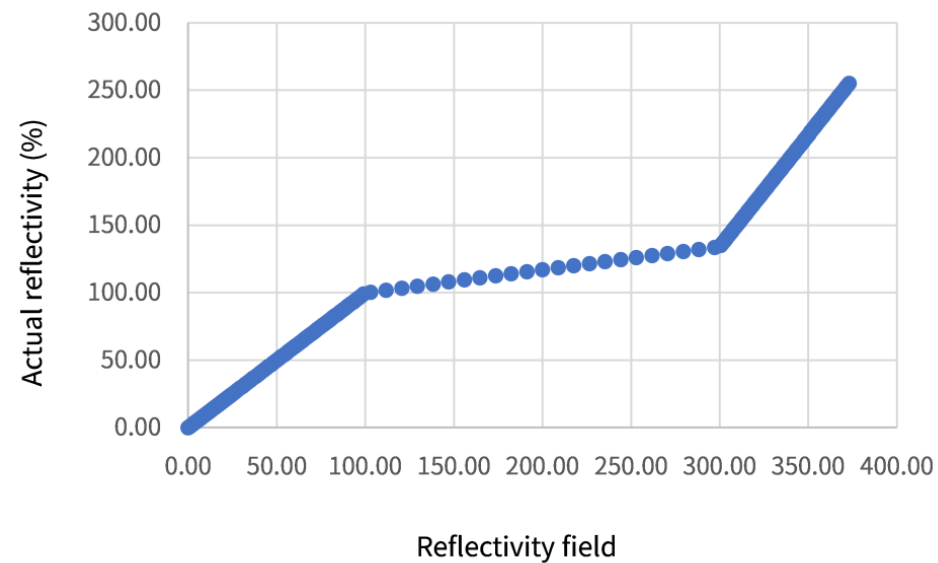

Figure 27. Nonlinear Mapping

Nonlinear Mapping

Reflectivity field	Actual reflectivity (%)	Reflectivity field	Actual reflectivity (%)
0.00	0.00	65.65	65.65
0.25	0.25	67.10	67.10

Reflectivity field	Actual reflectivity (%)	Reflectivity field	Actual reflectivity (%)
0.50	0.50	68.55	68.55
0.75	0.75	70.00	70.00
1.00	1.00	71.45	71.45
1.25	1.25	72.90	72.90
1.50	1.50	74.35	74.35
1.75	1.75	75.81	75.81
2.00	2.00	77.26	77.26
2.25	2.25	78.71	78.71
2.50	2.50	80.16	80.16
2.75	2.75	81.61	81.61
3.00	3.00	83.06	83.06
3.25	3.25	84.52	84.52
3.50	3.50	85.97	85.97
3.75	3.75	87.42	87.42
4.00	4.00	88.87	88.87
4.25	4.25	90.32	90.32
4.50	4.50	91.77	91.77
4.75	4.75	93.23	93.23
5.00	5.00	94.68	94.68
5.25	5.25	96.13	96.13
5.50	5.50	97.58	97.58

Reflectivity field	Actual reflectivity (%)	Reflectivity field	Actual reflectivity (%)
5.75	5.75	99.03	99.03
6.00	6.00	102.94	100.50
6.25	6.25	111.76	102.00
6.50	6.50	120.59	103.50
6.75	6.75	129.41	105.00
7.00	7.00	138.24	106.50
7.25	7.25	147.06	108.00
7.50	7.50	155.88	109.50
7.75	7.75	164.71	111.00
8.00	8.00	173.53	112.50
8.25	8.25	182.35	114.00
8.50	8.50	191.18	115.50
8.75	8.75	200.00	117.00
9.00	9.00	208.82	118.50
9.25	9.25	217.65	120.00
9.50	9.50	226.47	121.50
9.75	9.75	235.29	123.00
10.00	10.00	244.12	124.50
10.25	10.25	252.94	126.00
10.50	10.50	261.76	127.50
10.75	10.75	270.59	129.00

Reflectivity field	Actual reflectivity (%)	Reflectivity field	Actual reflectivity (%)
11.00	11.00	279.41	130.50
11.25	11.25	288.24	132.00
11.50	11.50	297.06	133.50
11.75	11.75	300.60	135.00
12.00	12.00	301.51	136.50
12.25	12.25	302.41	138.01
12.50	12.50	303.32	139.51
12.75	12.75	304.22	141.01
13.00	13.00	305.13	142.51
13.25	13.25	306.03	144.01
13.50	13.50	306.94	145.52
13.75	13.75	307.84	147.02
14.00	14.00	308.75	148.52
14.25	14.25	309.65	150.02
14.50	14.50	310.56	151.53
14.75	14.75	311.46	153.03
15.00	15.00	312.37	154.53
15.25	15.25	313.27	156.03
15.50	15.50	314.18	157.53
15.75	15.75	315.08	159.04
16.00	16.00	315.99	160.54

Reflectivity field	Actual reflectivity (%)	Reflectivity field	Actual reflectivity (%)
16.25	16.25	316.89	162.04
16.50	16.50	317.80	163.54
16.75	16.75	318.70	165.05
17.00	17.00	319.61	166.55
17.25	17.25	320.51	168.05
17.50	17.50	321.42	169.55
17.75	17.75	322.32	171.06
18.00	18.00	323.23	172.56
18.25	18.25	324.13	174.06
18.50	18.50	325.04	175.56
18.75	18.75	325.94	177.06
19.00	19.00	326.85	178.57
19.25	19.25	327.75	180.07
19.50	19.50	328.66	181.57
19.75	19.75	329.56	183.07
20.00	20.00	330.47	184.58
20.25	20.25	331.37	186.08
20.50	20.50	332.28	187.58
20.75	20.75	333.18	189.08
21.00	21.00	334.09	190.58
21.25	21.25	334.99	192.09

Reflectivity field	Actual reflectivity (%)	Reflectivity field	Actual reflectivity (%)
21.50	21.50	335.90	193.59
21.75	21.75	336.80	195.09
22.00	22.00	337.71	196.59
22.25	22.25	338.61	198.10
22.50	22.50	339.52	199.60
22.75	22.75	340.42	201.10
23.00	23.00	341.33	202.60
23.25	23.25	342.23	204.10
23.50	23.50	343.14	205.61
23.75	23.75	344.04	207.11
24.00	24.00	344.95	208.61
24.25	24.25	345.85	210.11
24.50	24.50	346.76	211.62
24.75	24.75	347.66	213.12
25.00	25.00	348.57	214.62
26.45	26.45	349.47	216.12
27.90	27.90	350.38	217.62
29.35	29.35	351.28	219.13
30.81	30.81	352.19	220.63
32.26	32.26	353.09	222.13
33.71	33.71	354.00	223.63

Reflectivity field	Actual reflectivity (%)	Reflectivity field	Actual reflectivity (%)
35.16	35.16	354.90	225.14
36.61	36.61	355.81	226.64
38.06	38.06	356.71	228.14
39.52	39.52	357.62	229.64
40.97	40.97	358.52	231.14
42.42	42.42	359.43	232.65
43.87	43.87	360.33	234.15
45.32	45.32	361.24	235.65
46.77	46.77	362.14	237.15
48.23	48.23	363.05	238.66
49.68	49.68	363.95	240.16
51.13	51.13	364.86	241.66
52.58	52.58	365.76	243.16
54.03	54.03	366.67	244.66
55.48	55.48	367.57	246.17
56.94	56.94	368.48	247.67
58.39	58.39	369.38	249.17
59.84	59.84	370.29	250.67
61.29	61.29	371.19	252.18
62.74	62.74	372.10	253.68
64.19	64.19	373.00	255.18

Appendix D: Legal notice

Copyright © 2017-2026 Hesai Technology Co., Ltd.

All rights reserved. Use or reproduction of this manual in parts or its entirety in any form or by any means without the written authorization of Hesai is prohibited.

Hesai Technology makes no representations or warranties, either expressed or implied, with respect to the contents hereof and specifically disclaims any warranties, merchantability, or fitness for any particular purpose. Further, Hesai Technology reserves the right to revise this publication and to make changes from time to time in the contents hereof without obligation to notify any person of such revisions or changes.

HESAI and HESAI logo are registered trademarks of Hesai Technology. All other trademarks, service marks, and company names in this manual or on Hesai's official website are properties of their respective owners.

The software included in this product contains copyright that is registered under Hesai Technology. Any third party is not permitted, except as expressly permitted by the licensor or expressly required by applicable law, to decompile, reverse engineer, disassemble, modify, rent, lease, loan, distribute, sublicense, create derivative works based on the whole or any part of the software.

Hesai Product Warranty Service Manual is on the Warranty Policy page of Hesai's official website: <https://www.hesaitech.com/warranty-policy/>

Hesai Technology Co., Ltd.

Phone: +86 400 805 1233

Website: www.hesaitech.com

Address: Building A, Haisu Culture Plaza, Shanghai, China

Business Email: info@hesaitech.comService

Email: service@hesaitech.com